

# SCIENCE FROM SCRAP

Written by  
Arvind Gupta

Illustrated by  
Chimayee Samant

# SCIENCE FROM SCRAP

WRITTEN BY  
ARVIND GUPTA

ILLUSTRATIONS  
CHINMAYEE SAMANT

Dedicated to my wonderful  
colleagues Vidula, Ashok and  
Shivaji.



## SCIENCE FROM SCRAP

Piles of garbage grow and grow  
For all we do is use and throw.

You can do a lot with less  
Using trash and throwaway mess.

Plastic bottles, Ice-cream sticks  
Tetrapaks, all free for picks.

Pick this junk, there is no dearth  
And in the process clean the earth.

Do not worry, don't waste cash  
Learn to make, Toys from Trash.

Joys and thrills come fairly cheap  
A spinning top all yours to keep.

Many toys don't cost the earth  
Self made toys have golden worth.

So pick up junk and make a toy  
Hands-on science you'll enjoy.

---

# Activities

1. CD-Gyroscope	.....5
2. CD-Hovercraft	.....6
3. CD-Top	.....7
4. Balloon Blast	.....8
5. Balloon Burst	.....9
6. Balloon Centrifuge	.....10
7. Balloon Spinner	.....11
8. Jumping Bug	.....12
9. Paper Bugs	.....13
10. Elephant's Trunk	.....14
11. Straw Spinner	.....15
12. Straw Waves	.....16
13. Straw Sprinkler	.....17
14. Pen Pump	.....18
15. Squeeze Pump	.....19
16. Balancing Ballerina	.....20
17. Balancing Forks	.....21
18. Balancing Pipe	.....22
19. Bernoulli's Bag	.....23
20. Auto Siphon	.....24
21. Bottle Box	.....25
22. Bottle Planters	.....26
23. Constant Flow	.....27

24. Daredevil Diver	.....	28-29
25. Height Might	.....	30
26. Free Fall	.....	31
27. Obedient Bottle	.....	32
28. Six Legged Spider	.....	33
29. Terrific Tornado	.....	34
30. Fountain Jet	.....	35
31. Bottle Propellor	.....	36-37
32. Wind Generator	.....	38-39
33. Crank Generator	.....	40-41
34. Syringe Torch	.....	42
35. Simplest Motors	.....	43
36. Magnetic Diver	.....	44
37. Standing Spinning Pencil	.....	45
38. Pencil box Periscope	.....	46
39. Head-On Hit	.....	47
40. Nut Spinner	.....	48
41. Spiral Snake	.....	49
42. Woodpecker	.....	50
43. Mouth Organ	.....	51
44. Paper Clip Top	.....	51
45. Dog Puppet	.....	52
46. Sewing Machine	.....	53
47. Merry-Go-Round	.....	54
48. Minute Measurements	.....	55
49. Newspaper Bin	.....	56-57
50. Simple Mecanno	.....	58-59



## CD - GYROSCOPE

YOU NEED

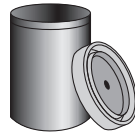

Film can



Thread



Old CD



Rubber Glue



Scissors

1

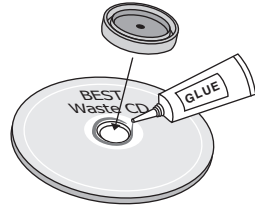

Stick the flat face of a film can lid to the center of an old CD. Make a hole in the middle of the lid.

2

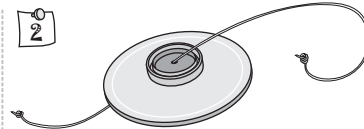

Weave a thread and tie knots at its ends. The thread should be free in the hole.

3

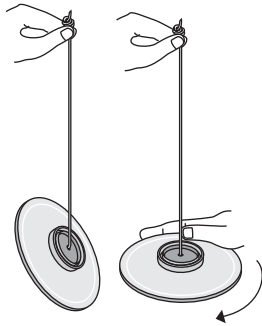

Hang the CD by one end of the thread. The CD at rest will turn "vertical" and hang at an angle. Now hold the thread with one hand and spin the CD with the other. Swing it from left to right.

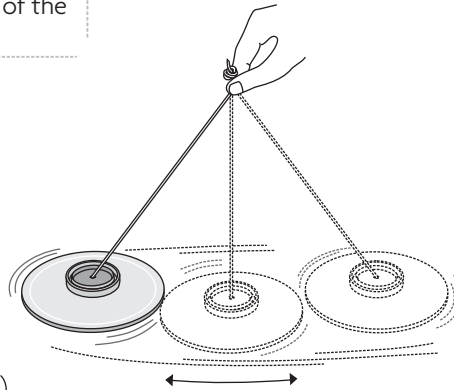

You will be surprised that the plane in which the CD rotates does not change even as the thread inclines to the left or right. The "spinning" CD acts like a gyroscope.



# CD - HOVERCRAFT

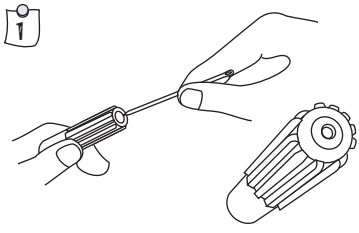
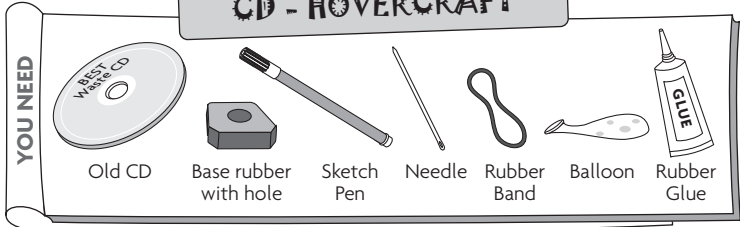

Make a hole in an old sketch pen lid with a long needle.

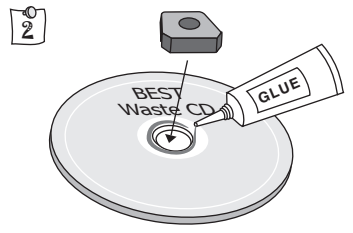

Stick a piece of rubber with a hole in the center of an old CD.

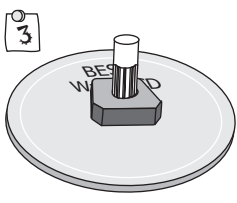

Press fit the pen lid in the rubber hole.

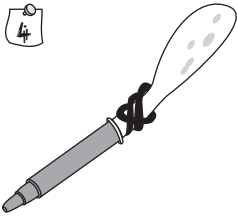

Fix a balloon with a rubber band to a 4-cm long sketch pen tube.

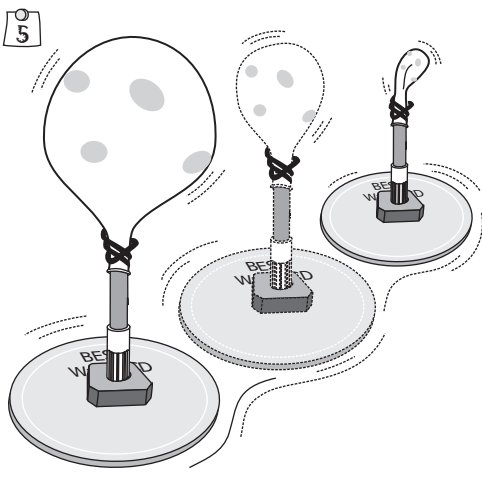

Inflate the balloon and place the sketch pen in its lid. Now place the CD on a smooth floor and give it a little push. The CD will glide on a cushion of air just like a Hovercraft.

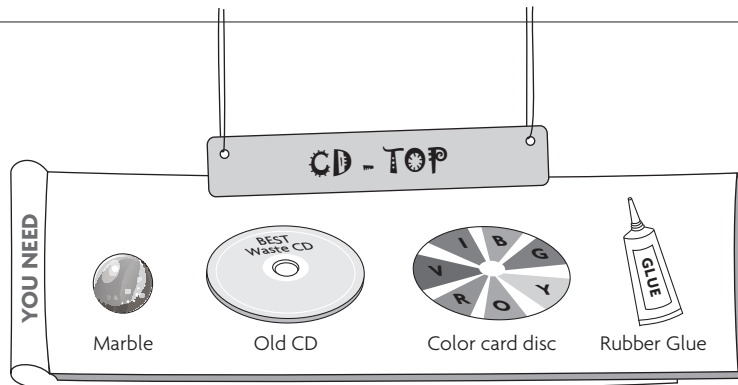

Stick a marble in the CD hole with rubber glue. Allow the glue to dry.

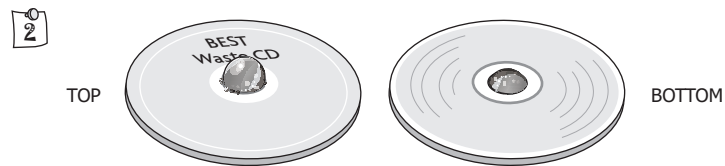



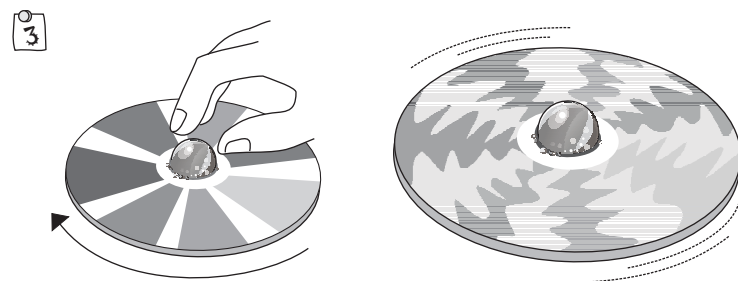

The top of the marble will provide the grip for spinning the CD. The CD top will spin on the marble pivot. It's an ideal top - with a low center of gravity and large moment of inertia.



Stick a Newton's Color card disc on the CD. On spinning the CD top the colors will mix and you will see a grayish-white.

# BALLOON BLAST

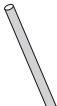
**YOU NEED**

				
Balloon	Thread	6-cm Straw	Cello tape	Scissors

**1**

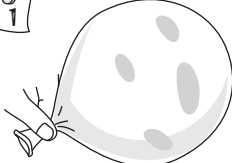

Inflate a balloon and close its mouth with your hand.

**2**

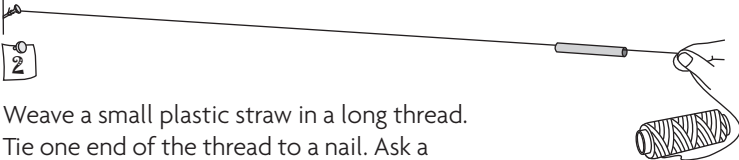

Weave a small plastic straw in a long thread. Tie one end of the thread to a nail. Ask a friend to pull the other end.

**3**

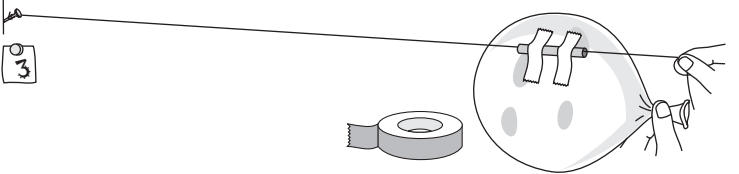

Tape the balloon to the straw. Then release the balloon. Air will eject out of the mouth like a jet and will propel the balloon along the thread like a rocket.

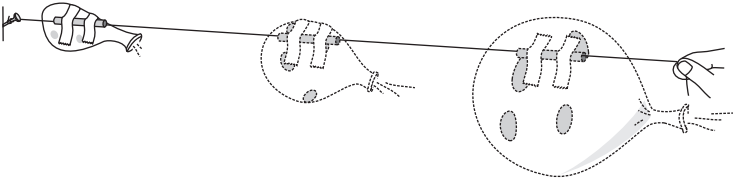

The diagram shows three stages of the balloon's movement. In the first stage, the balloon is at the right end of the thread, with air being ejected from its mouth. In the second stage, the balloon has moved to the left. In the third stage, the balloon has moved further to the left, and the thread is shown as a dashed line, indicating it is no longer visible.

# BALLOON BURST

YOU NEED



Balloon



Needle



Cello tape

1

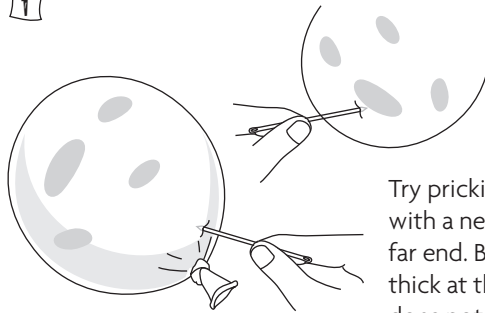

Try pricking an inflated balloon with a needle near its mouth or far end. Because the rubber is thick at these points the balloon does not burst.

2

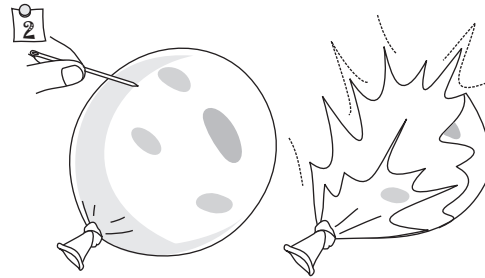

However if you poke the balloon with a needle near the highly stretched center it will burst with a loud bang!

3

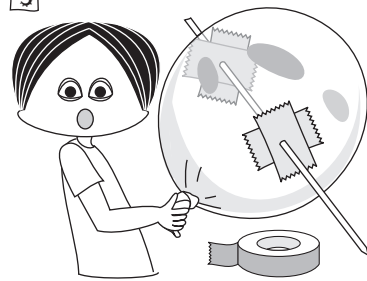

Stick cello tapes across two diametrical points of the balloon. Poke a sharp cycle spoke through. The balloon will not burst. The tape prevents the balloon skin from retracting and bursting.

## BALLOON CENTRIFUGE

YOU NEED



Transparent Balloon



Coin



Nut

1

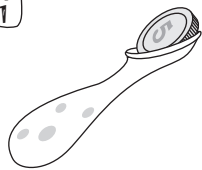

Take a transparent balloon and place a coin in it.

2

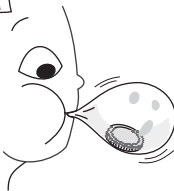

Inflate the balloon.

3

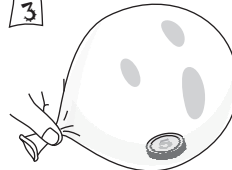

Close the mouth of the balloon with your hand.

4

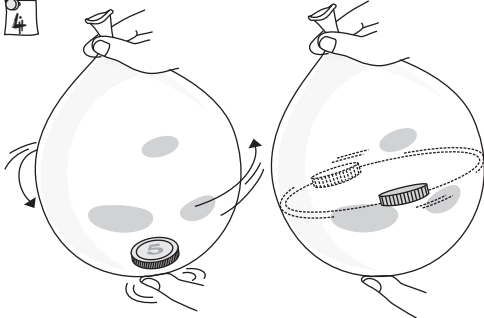

Give the balloon circular motion and make the coin spin. The coin will spin smoothly around in circles - like a motor cycle in a circus cage.

5

Replace the coin with a hex-nut. The spinning nut will make a roaring sound! The coin and nut rotate inside the balloon because of Centrifugal Force.

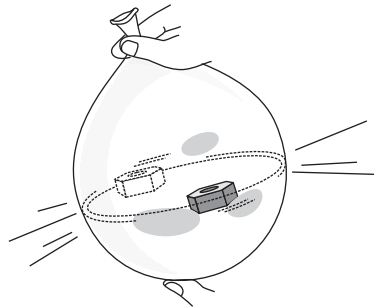

# BALLOON SPINNER

YOU NEED

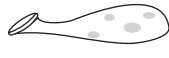

Balloon

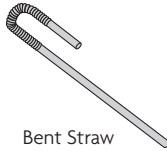

Bent Straw



Rubber Bands



Scissors

1

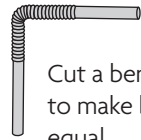
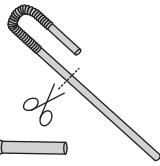

Cut a bent straw to make both legs equal.

2

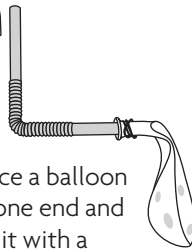

Place a balloon in one end and tie it with a rubber band.

3

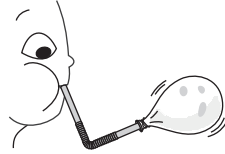

Inflate the balloon.

4

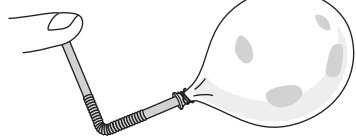

Close the end of the straw with your finger and place it on the floor.

5

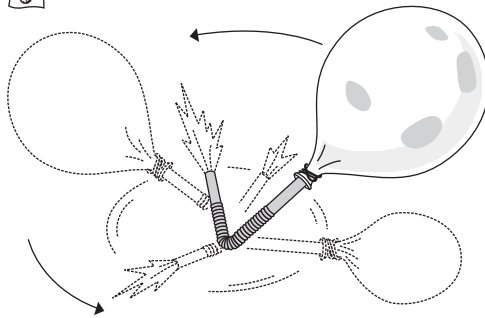

Air will eject from the end of the straw and the balloon will rotate in circles.

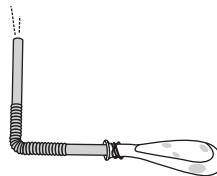

## JUMPING BUG

YOU NEED



Card Bug

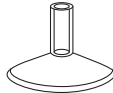

Suction cup



Old Bottle



Scissors



1 Cut a 1-cm wide ring from an old plastic bottle.

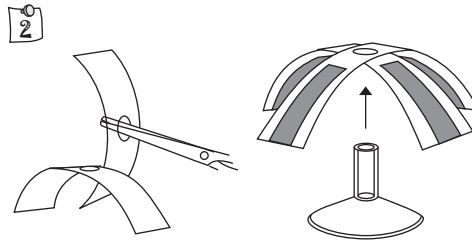

2 Cut ring in two halves and make holes in the center. Insert a small suction cup in the holes to make the Bug.

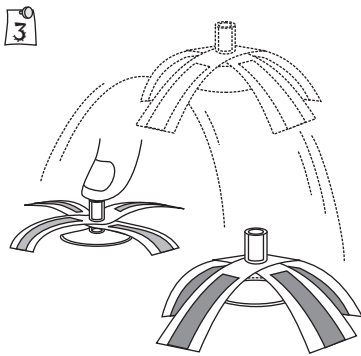

3 Place Bug on the table. Then press the suction cup down and release. The Bug will flatten and then jump up. The legs act like a spring.

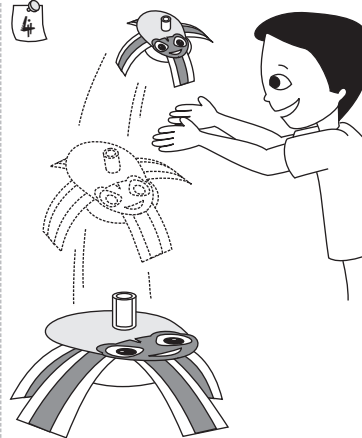

4 Draw a card Bug and place it on top. Now press to make it jump and then catch it.

## PAPER BUGS

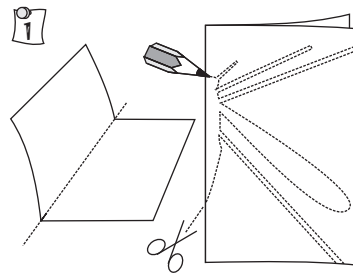
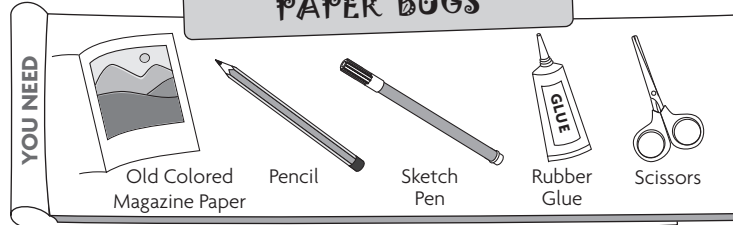

1 Take a smooth colorful dotted magazine paper. Double it. Draw half an insect and then cut it.

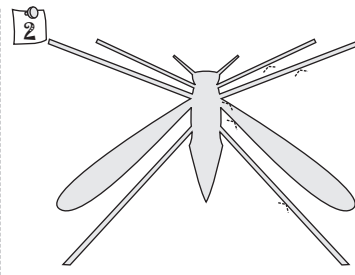

2 Open the insect - its antennae, front legs, main wing, hind legs and tail.

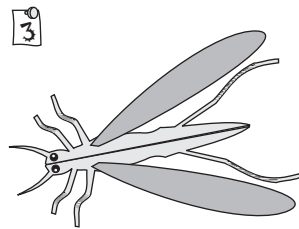

3 Bend the legs to give them shape. Draw eyes with a sketch pen.

4 Stand your bug on a card sheet and glue its legs. Look out for colorful magazine paper to make cockroaches, beetles and other insects.

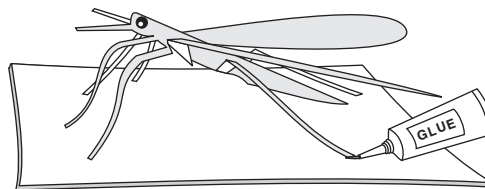



## ELEPHANT'S TRUNK

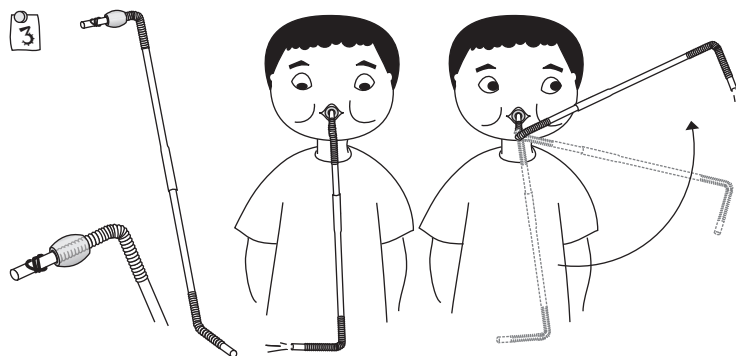
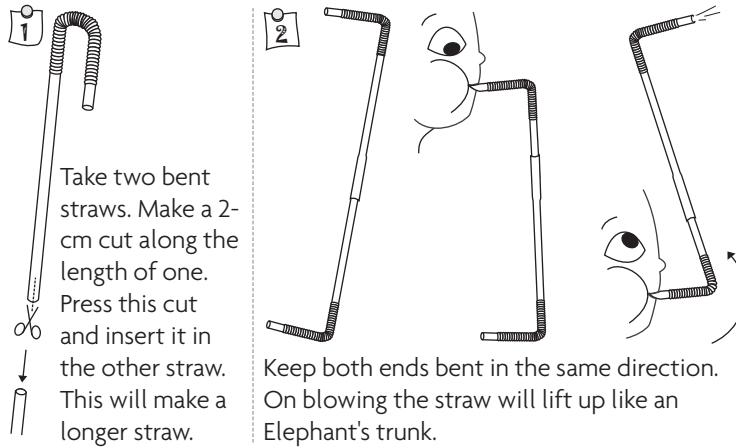
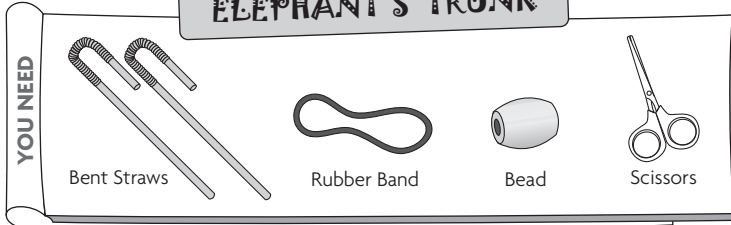

## STRAW SPINNER

YOU NEED

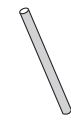

6-cm Straw



Thin Straw

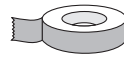

Cello tape



Scissors

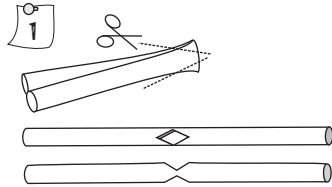

1  
Fold a 6-cm straw in half. Nip corners to make a diamond shaped hole in the center.

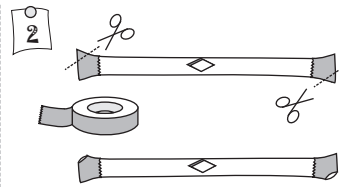

2  
Flatten ends and seal with tape. Nip diametrically opposite corners to make the spinner.

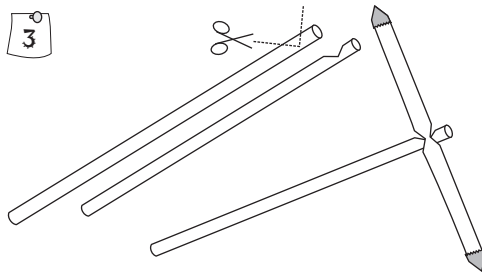

3  
Cut a 'V' notch near the end of the thin straw. Place the thin straw in the spinner. Close end with one finger. Then blow and enjoy the spin.



4  
Place spinner on the table and blow through the straw to make it spin round-and-round.

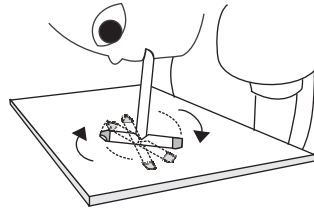

## STRAW WAVES

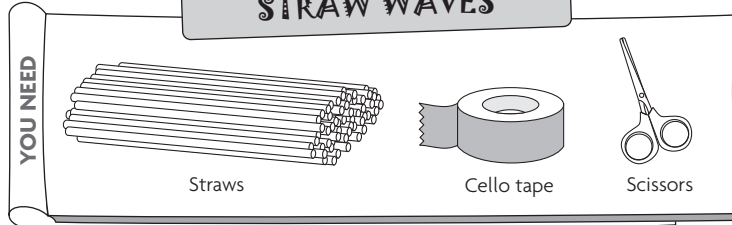

1

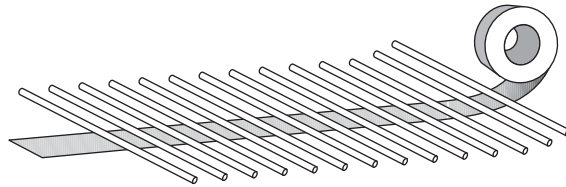

Stretch 1.5-m tape on the floor with its sticky side up. Stick 60 straws each 2-cm apart. Leave 5-cm of tape on both ends as a handle.

2

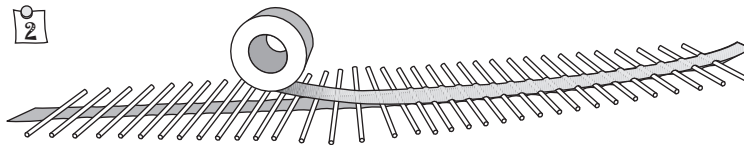

Stick another long tape on top so that all the straws are sandwiched between the two tapes.

3

Ask a friend to hold one end of the tape. You hold the other end tightly and give it a tap. A wave will travel along and will be reflected from the other end.

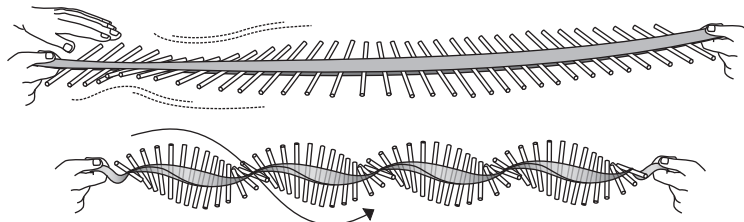

Induce “standing” waves by twisting the end tapes a few times. Now you can clearly see troughs and crests and wavelengths.

# STRAW SPRINKLER

YOU NEED

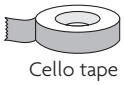
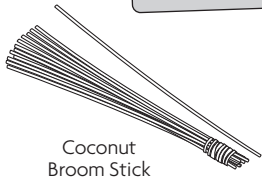

1

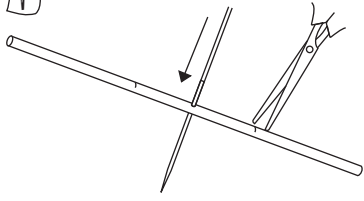

Poke the stick at right angles in the center of the straw. Mark two points 2-cm from the center and make half cuts.

2

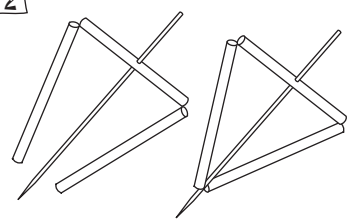

Bend the two arms of the straw to make a triangle.

3

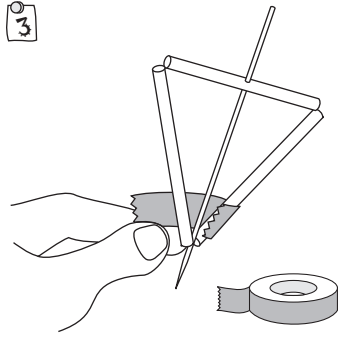

Stick the bent straw legs and the broom stick with a piece of cello tape.

4

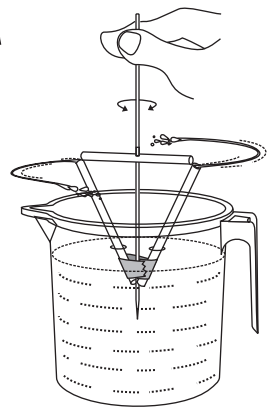

Place the triangle in water and spin the broom stick with one hand. Large chunks of water will sprinkle out from the straw cuts like a centrifuge.

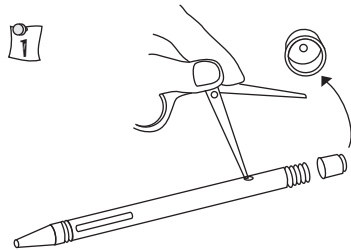
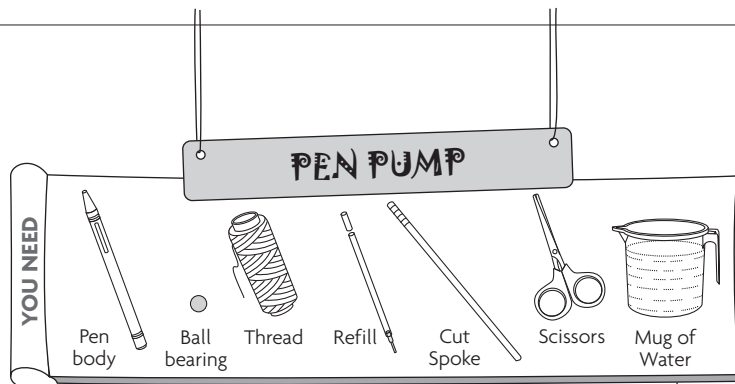

Make a hole in the end cap of an old pen so that a bicycle spoke can move freely in it. Make a small hole in the body of the ball pen for the delivery pipe.

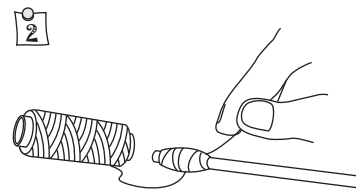

Tightly wrap thread on the cycle spoke to make a piston.

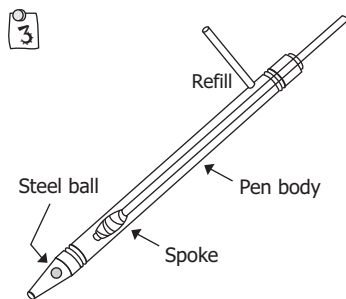

First drop the ball in the pen. Then insert the spoke-piston and finally screw the end cap. The refill should be inserted in the pen body in the end.

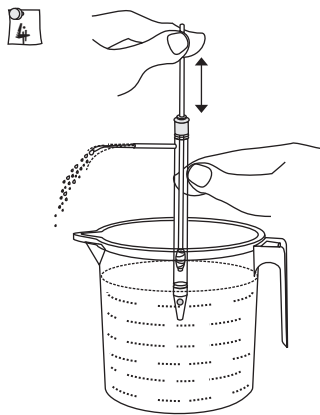

Place the Pen Pump in a mug of water and move the bicycle spoke-piston up and down. After a few strokes water will come out with a gush from the delivery pipe.

## SQUEEZE PUMP

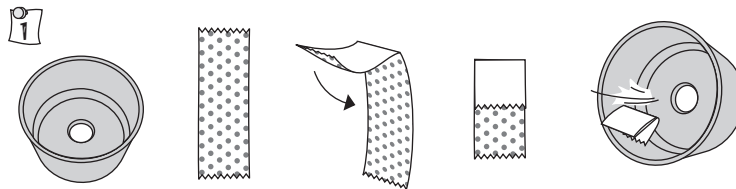
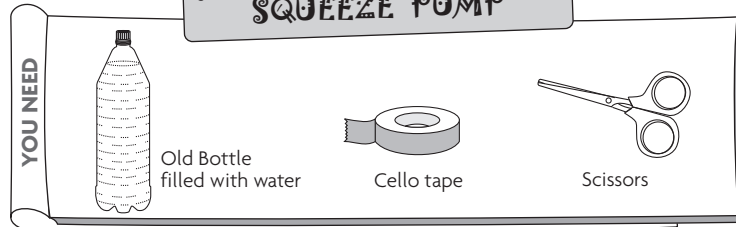

Make a hole in the bottle lid. Take 3-cm long tape. Stick 1-cm of the gluey side (with dots) on to itself. Stick the remaining gluey part in the lid to make a “flap” valve.

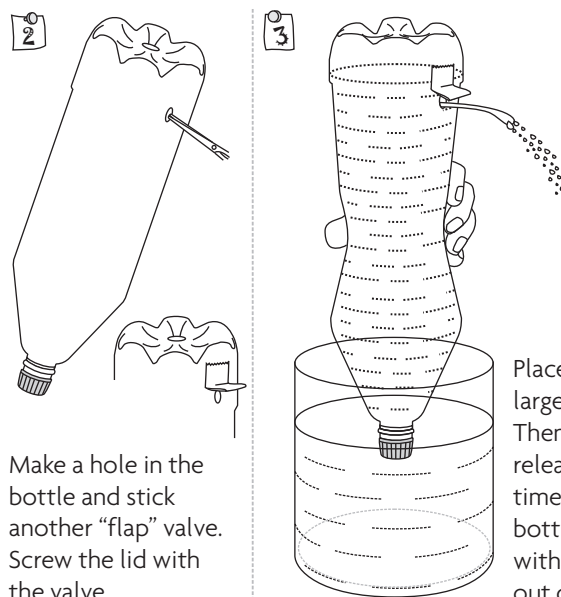

Make a hole in the bottle and stick another “flap” valve. Screw the lid with the valve.

Place the bottle in a large bowl of water. Then squeeze and release it several times. Soon the bottle will fill up with water and gush out of the hole.

## BALANCING BALLERINA

YOU NEED



Card Doll

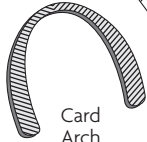

Card Arch

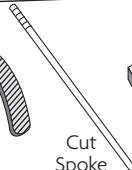

Cut Spoke



Steel Nuts



Rubber Glue



Scissors

1

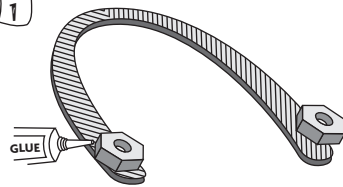

Make a thick card arch and stick two heavy steel nuts on its ends.

2

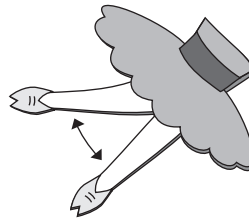

Make a card sheet Ballerina with notched shoes.

3



Join the arch to the Ballerina.

4

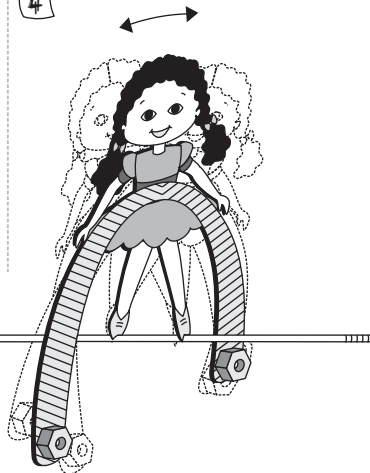

Phase out the legs of the Ballerina and balance them on a cycle spoke.

Because of the low centre of gravity the Ballerina will not fall and will rock on the spoke.

## BALANCING FORKS

YOU NEED



2 Forks



Old Bottle filled with sand

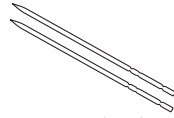

Toothpicks



Rubber Glue

1

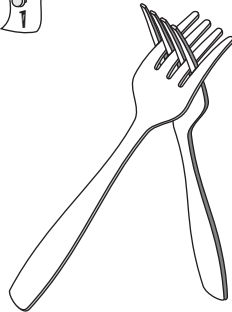

Interlock two forks tightly.

2

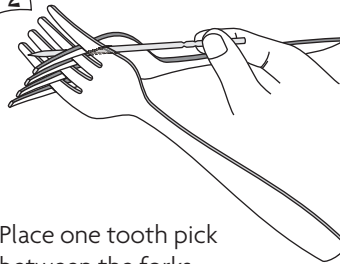

Place one tooth pick between the forks.

3

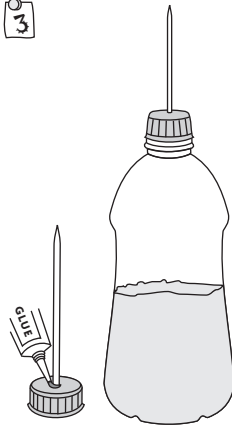

Poke a hole in a bottle lid and fix a tooth pick. Glue the tooth pick.

4

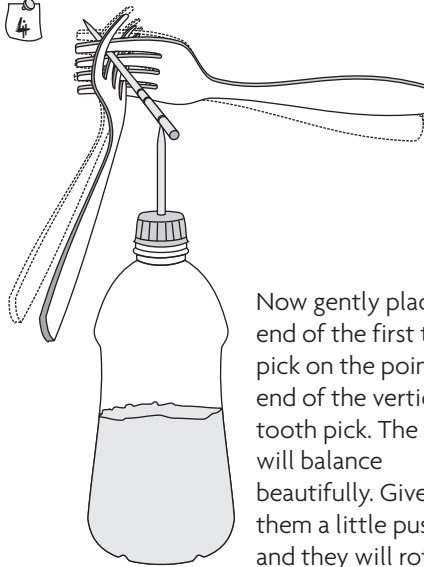

Now gently place the end of the first tooth pick on the pointed end of the vertical tooth pick. The forks will balance beautifully. Give them a little push and they will rotate.



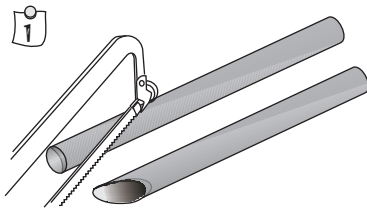
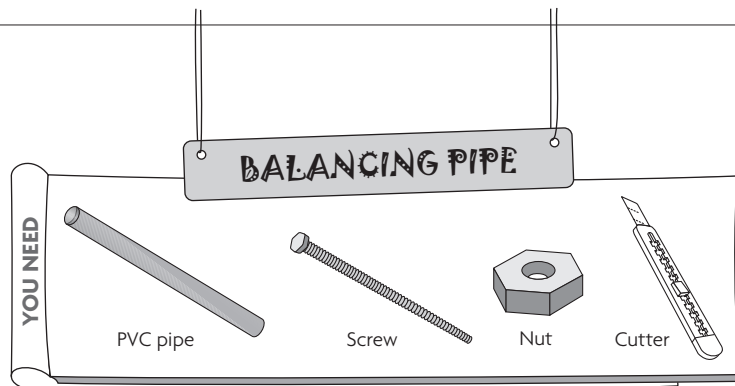

1 Cut one end of a 30-cm long PVC pipe at an angle of 45-degrees.

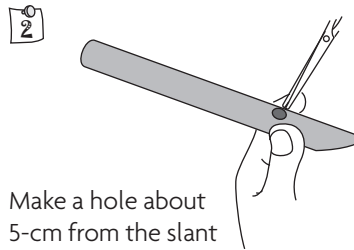

2 Make a hole about 5-cm from the slant end.

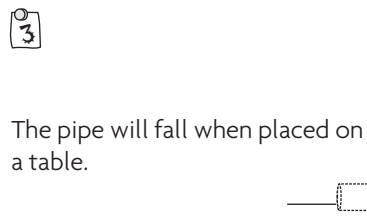

3 The pipe will fall when placed on a table.

4 You can balance the pipe by placing a long steel bolt in the hole. Slide the loose nut to adjust the balance. Similarly cut an old sketch pen at a slant and balance it by placing a screw-nut as a counterweight.

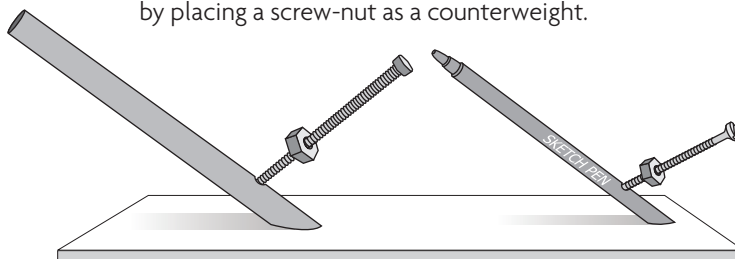

## BERNOULLI'S BAG

YOU NEED

Plastic Tube - 10-cm wide, 2-m long (used for making bags)

1

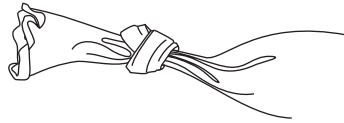

Tie a knot at one end of a 2-m long flexible plastic tube.

2

Take one deep breath and blow it into the tube. Hold the tube next to your mouth. This will be a measure of your lung capacity - approximately 3 liters.

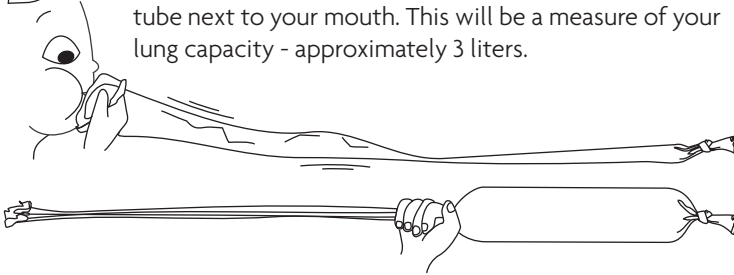

3

Next keep the tube end 15-cm away from your mouth. Again take a deep breath and blow. This time there will be much more air in the tube. The high velocity of the blown air creates a low pressure zone - sucking a lot of air from the outside.

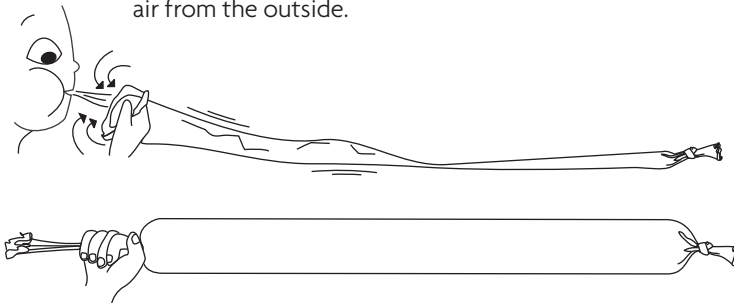

## AUTO SIPHON

YOU NEED



Old Bottle



Bent Straw



Rubber  
Glue

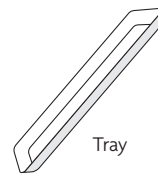

Tray

1

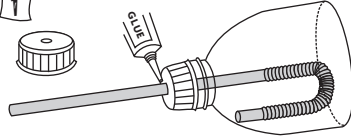

Fix a bent straw tightly in the lid of a half plastic bottle. Seal the straw joint with glue.

2

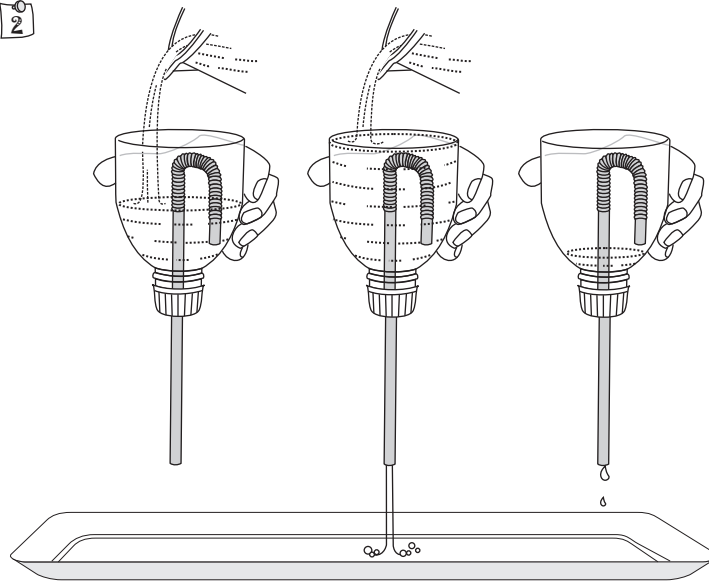

Pour water in the bottle. Initially no water will flow out. Only when the level reaches the top bend of the straw will water flow down. This makes an automatic siphon.

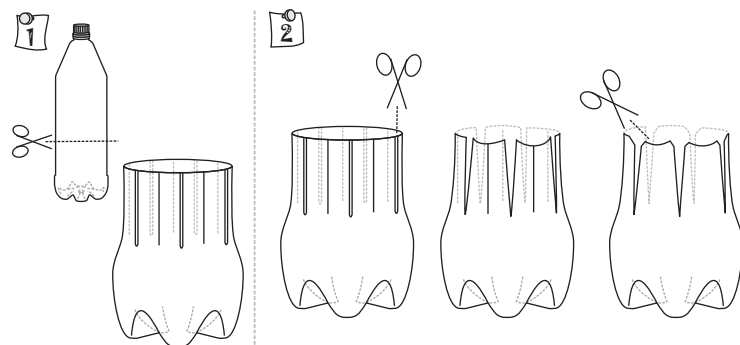
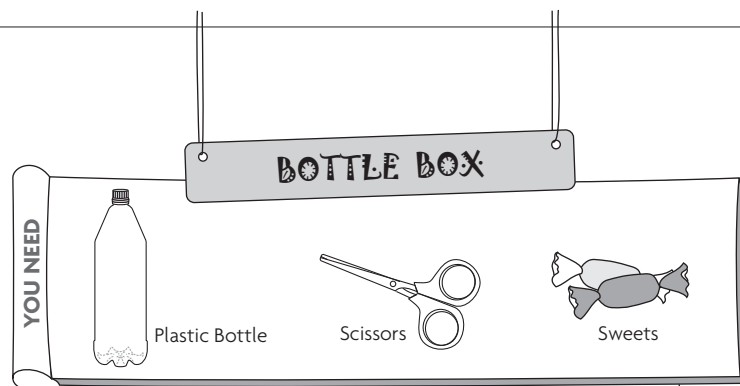

Cut a 2-liter empty plastic coke bottle 15-cm from the base.

Make 5 vertical cuts 5-cm long to make 5 petals. Cut the corners round with a scissors.

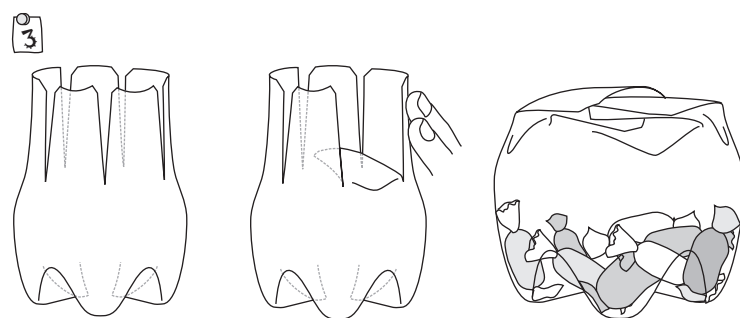

The 5 petals will make a good lid. Close the petals one-by-one. They will shut with a snap. Place some sweets in this wonderful "Bottle Box" and gift it to a friend.

## BOTTLE PLANTERS

YOU NEED



Old Plastic Bottles



Strong String



Needle



Scissors

1

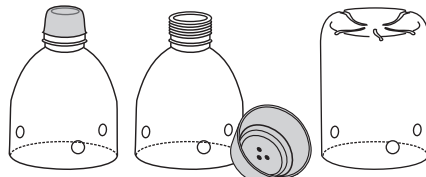

Cut two conical tops and one base from old plastic bottles. Make holes in the lids to drain the excess water.

2

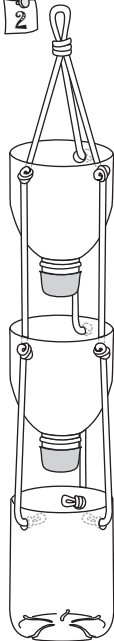

Join the cut bottles as shown with a strong string.

3

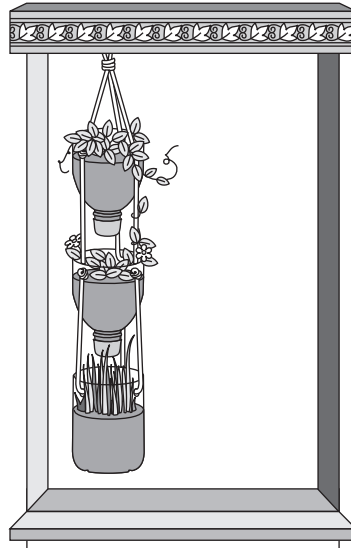

Place soil and grow plants. Hang the planter from a window sill. Don't forget to water it regularly.

## CONSTANT FLOW

YOU NEED

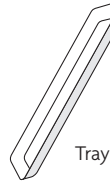
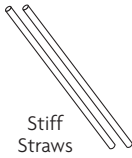

1

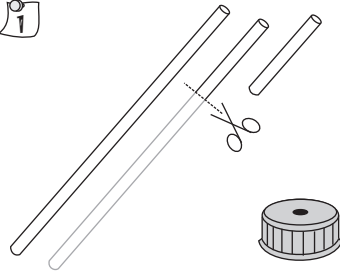

2

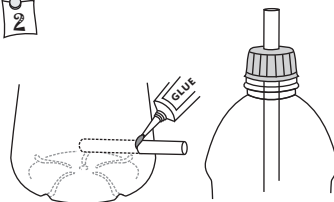

3

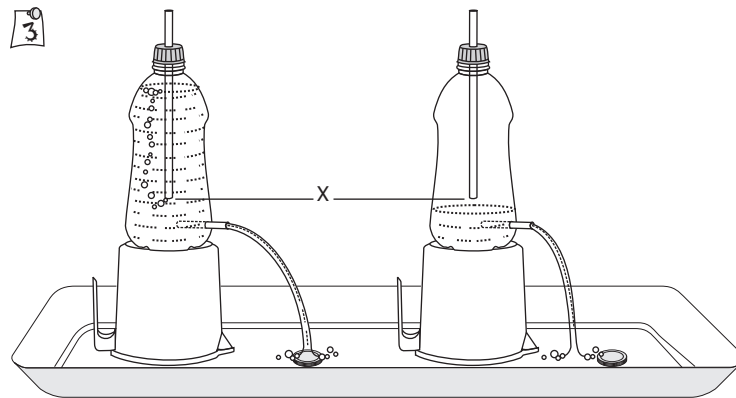

## DAREDEVIL DIVER

YOU NEED

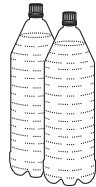

2 liter Bottles



Plastic Dropper



Cycle Nut



Rubber Band

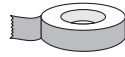

Cello tape



Scissors

1

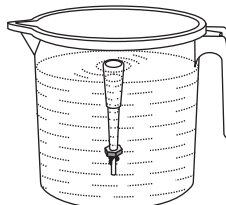
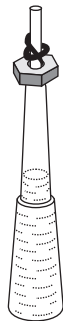

Place a cycle nut in a plastic dropper and tie it with a rubber band. Fill enough water in the dropper so that it just floats flush with the water level. The dropper will be critically balanced. It will neither pop out of water nor sink.

2

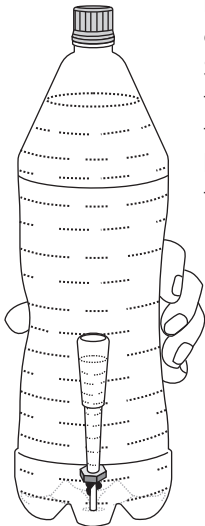
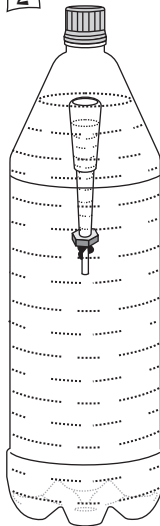

Place this "critically balanced" dropper in a 2-liter water bottle. Screw the lid tightly. On pressing the bottle a little water will enter the dropper making it slightly heavy. The dropper will dive to the bottom.



3 Make big holes in two bottle lids. Place them back-to-back and tape them to make a double lid.



4

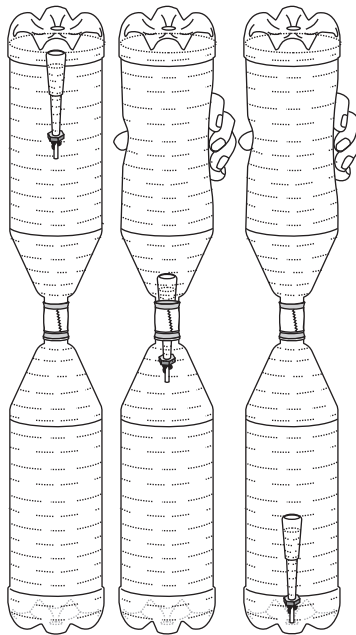

Assemble two bottles with water and the “critically balanced” dropper. On pressing the bottle the dropper will deep dive through the lids to reach the bottom. On releasing the pressure it will magically come up.

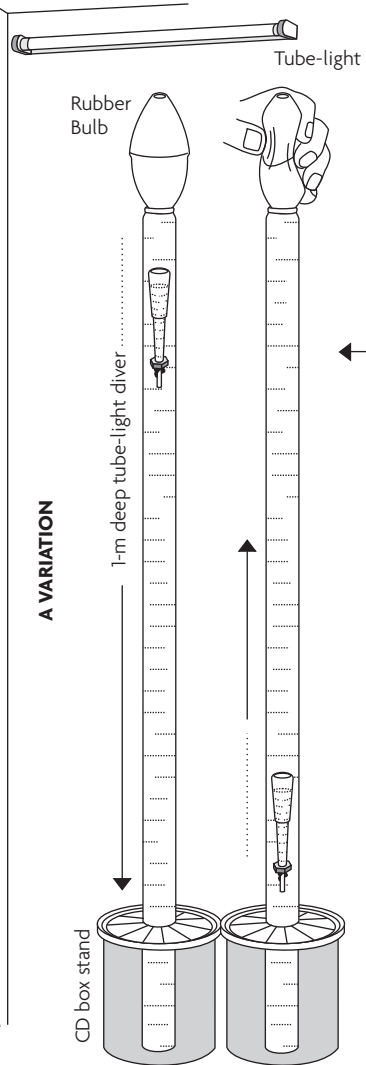



## HEIGHT MIGHT

YOU NEED



Plastic Bottles

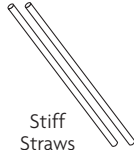

Stiff Straws



Rubber Glue



Scissors

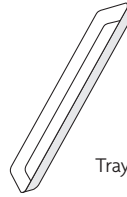

Tray

1

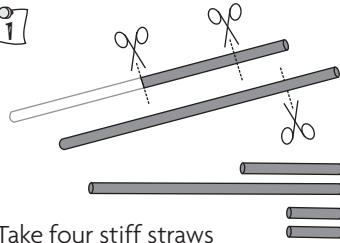

Take four stiff straws two 3-cm long, the other two 6-cm and 12-cm long.



2

Press fit them in two bottle lids. Apply glue for sealing.

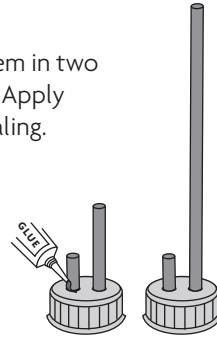

3

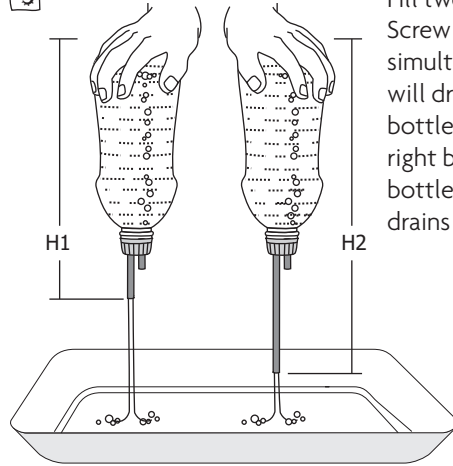

Fill two bottles fully with water. Screw the lids and invert them simultaneously. Which bottle will drain out first? The left bottle has a head  $H_1$ , while the right bottle has a head  $H_2$ . The bottle with the greater head drains out first.

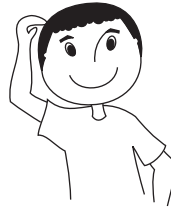

## FREE FALL

YOU NEED

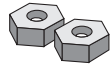

Steel Nuts



Rubber Bands



Half Bottle with hole in lid



Scissors

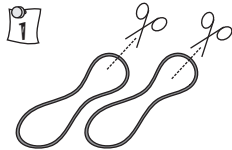

1  
Cut two rubber bands.

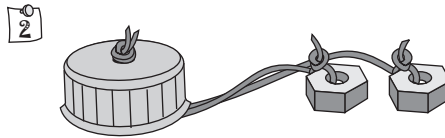

2  
Tie cycle nuts to one end of the rubber bands. Tie their other ends to a bottle lid.

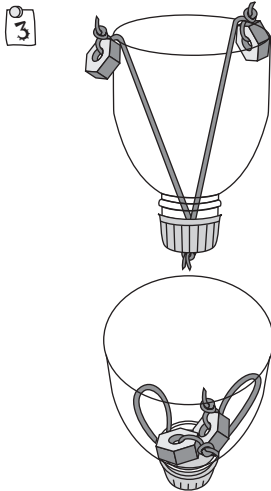

3  
Place the nuts as shown and drop the half bottle from a height. Ask a friend to catch it. She will be surprised to find the nuts inside the bottle. This is because the assembly become "weightless" when in free fall and then the tension in the rubber bands pulls the nuts inside the bottle.

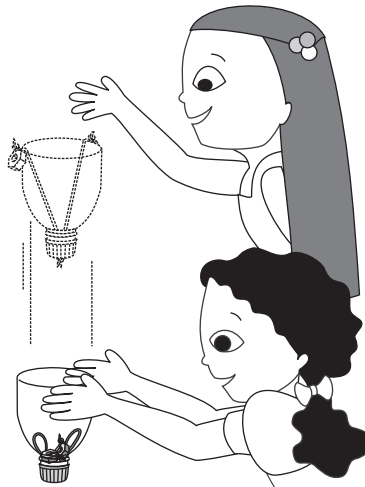

## OBEDIENT BOTTLE

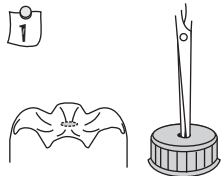
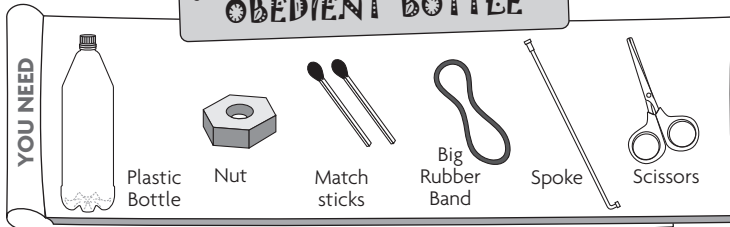

Make a hole in the bottle lid and also in its base.

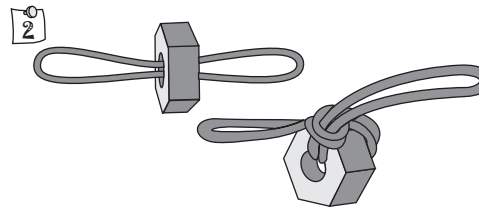

Slip a long rubber band in a heavy hex-nut and tie a knot.

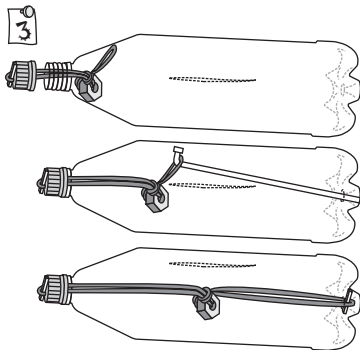

Cut a slit in the bottle to slip in the hex-nut and rubber band. Attach the left end of the rubber band with a matchstick to the lid. Pull the other end with the hook of a cycle spoke. Fix it to the base of the bottle with a matchstick.

**4**

If you roll the bottle on the ground it will go a little distance and then surprisingly return back! When the bottle goes forwards the rubber band winds. When it unwinds the bottle returns.

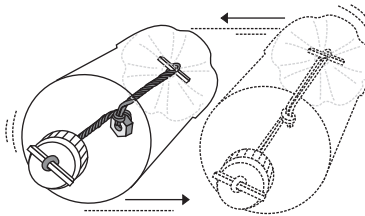

## SIX LEGGED SPIDER

YOU NEED



Bottle base



Bottle Lid



Straw Piece

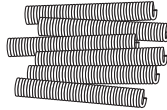

Plastic Spirals



Sketch Pen



Rubber Glue



Scissors

1

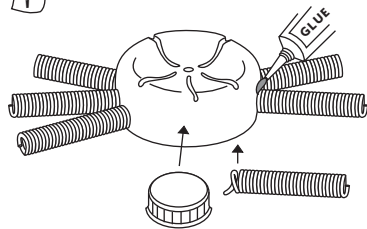

Cut 4-cm from the base of an old plastic bottle. Attach plastic spirals to the base to make the spider's legs.

2

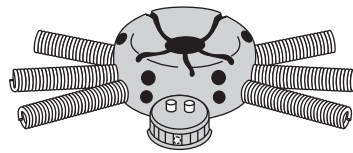

Glue a bottle lid to make the spider's head. Fix two straw eyes and draw a mouth to complete the spider.

3

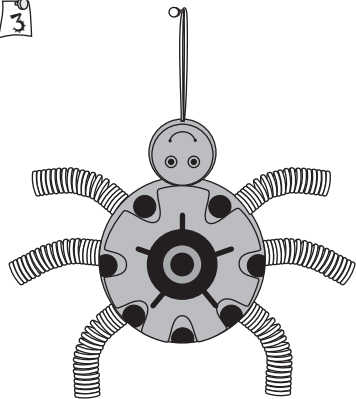

Paint and decorate your spider. Hang it on the wall by a nail.

## TERRIFIC TORNADO

YOU NEED

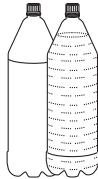

2 liter bottles



Cello tape



Scissors

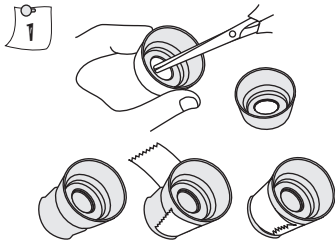

1  
Make neat round holes in two bottle lids with a scissors. Tape these lids back-to-back. Ensure there is no leakage of water.

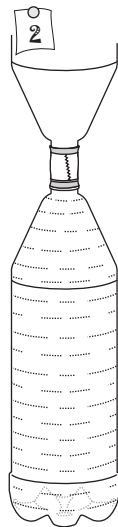

2  
Screw this double lid to a 2-liter bottle filled with water. Screw an empty 2-liter bottle on top.

Invert the bottles and shake them. Water will start swirling in the top bottle like a tornado. It will make a deep cone and fall below. The motion appears as if a black-hole is "sucking" in matter!

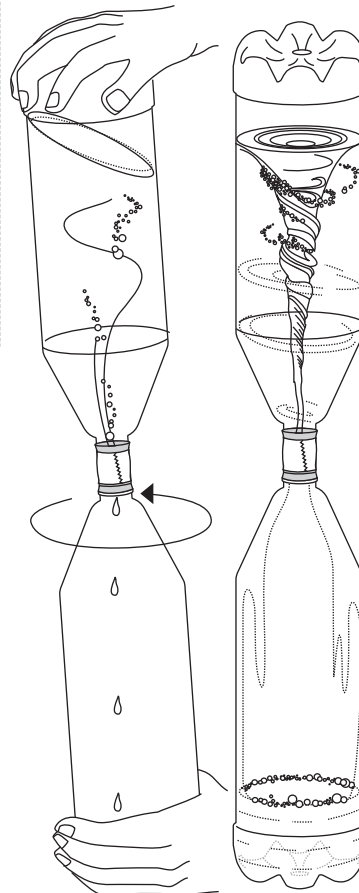

## FOUNTAIN JET

YOU NEED

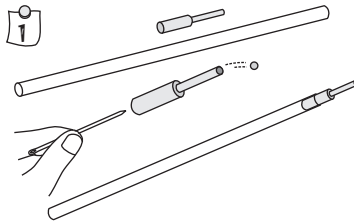
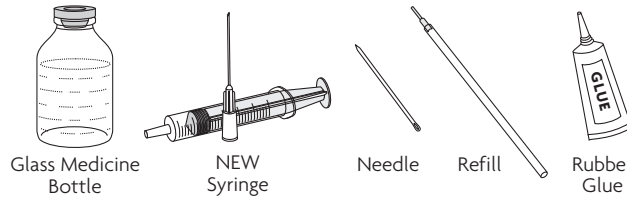

1 Remove the brass tip of an old ball pen refill. Push the ball out of the tip with a needle. Now the tip will have a jet like orifice.

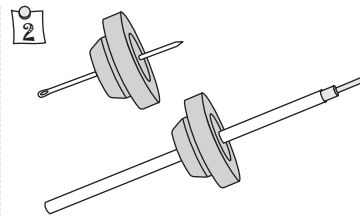

2 Make a hole in the rubber lid. Then press fit the ball point refill.



3 Fill the glass bottle with water and then fix its lid. Also bend and push the needle of a NEW syringe in the lid.

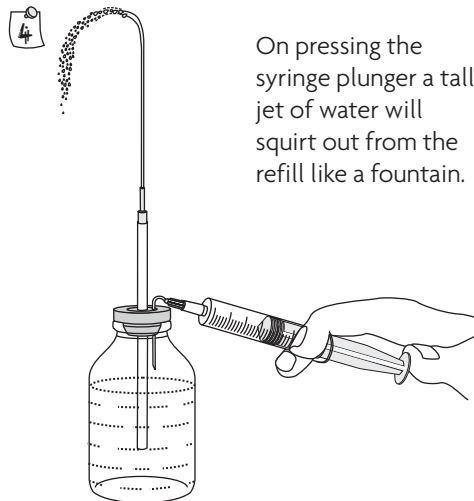

4 On pressing the syringe plunger a tall jet of water will squirt out from the refill like a fountain.

## BOTTLE PROPELLER

YOU NEED



Plastic Bottles



Base rubber with hole

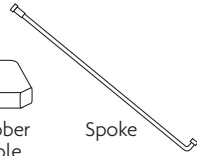

Spoke



Scissors

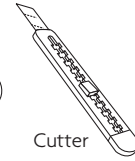

Cutter

1

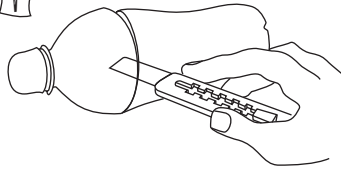

Cut a plastic bottle top to make the fan.

2

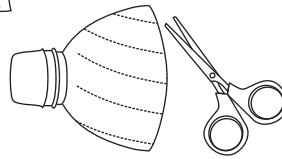

Cut 12 petals at a slant.

3

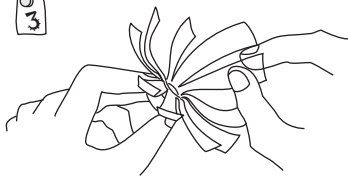

Twist and curve each petal to make fan blades.

4

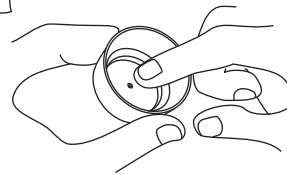

Make a dent in the middle of the lid.

5

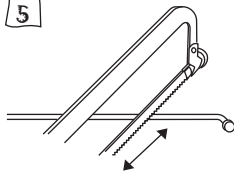

Cut a cycle spoke slightly longer than the bottle height.

6



File / rub spoke on stone to make one end pointed.

7

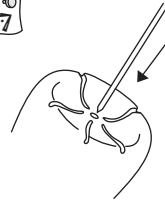

Make a smooth hole in the base of the bottle.

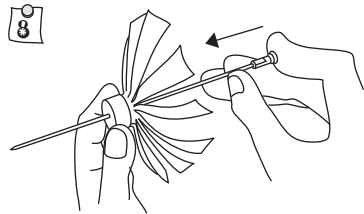

Press fit a bicycle spoke nut in the center of the bottle lid.

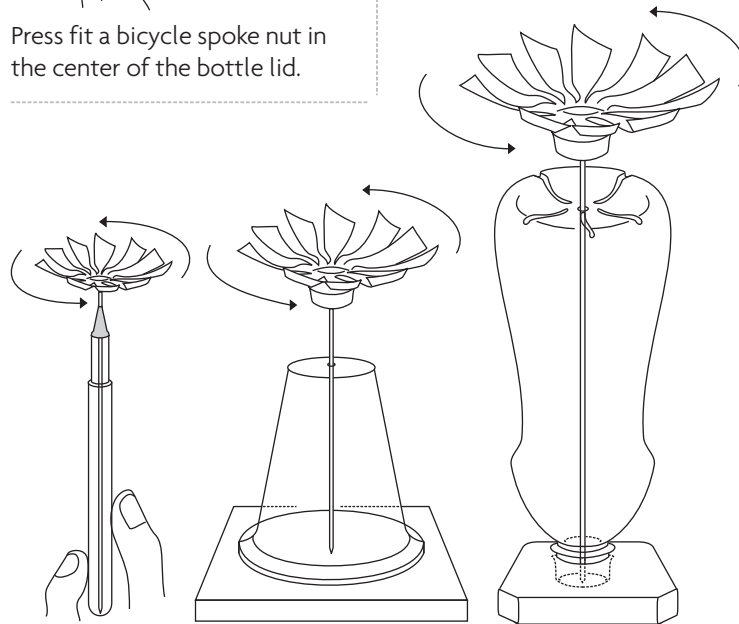
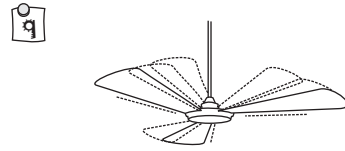

**DIFFERENT VARIATIONS**

Place these assemblies under a ceiling fan. In each case the propeller will spin very fast.





# WIND GENERATOR

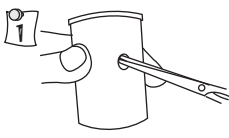
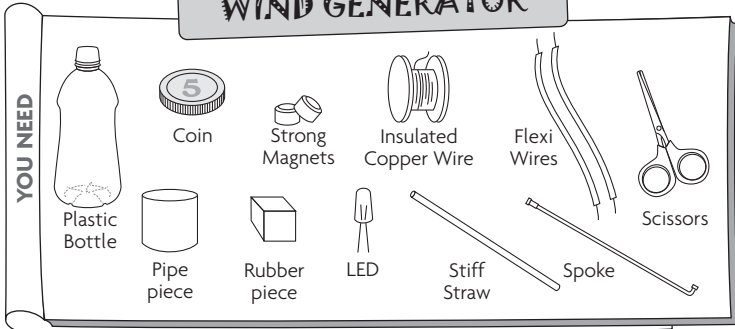

1 Make a through hole in the pipe.

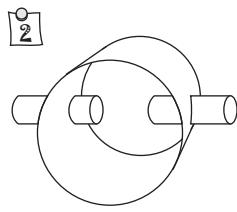

2 Press fit pieces of stiff straw as bush bearings.

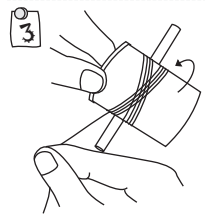

3 Wind 500 turns of thin insulated Copper wire.

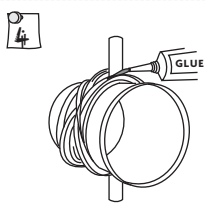

4 Apply glue to keep the coil windings adhered.

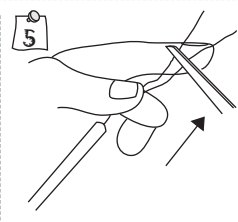

5 Scrape the insulation from the two ends of the coil.

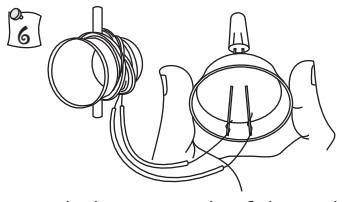

6 Attach the two ends of the coil to a LED.

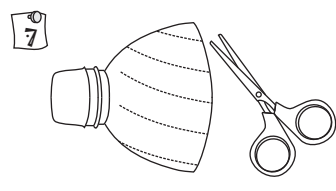

7 Cut a plastic bottle top to make the fan.

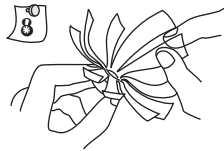

8  
Cut 12 petals. Twist them to make fan blades.



9  
Press fit a spoke nipple nut in the bottle lid.

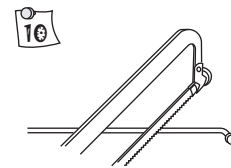

10  
Cut cycle spoke.

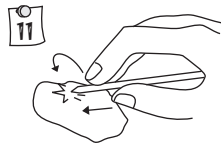

11  
File / rub on stone to make one end pointed.

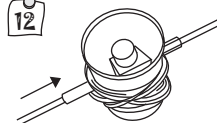

12  
Place spoke in rubber piece. Attach two strong magnets to the rubber.

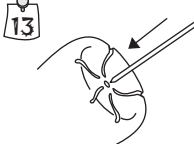

13  
Make a smooth hole in the base of the bottle.

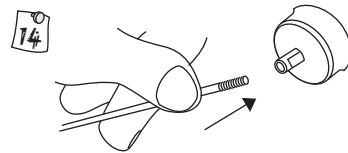

14  
Tighten spoke to the nipple nut embedded in the bottle lid.

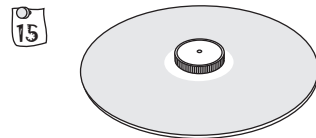

15  
Stick coin with a dimple in the middle of the CD.

Assemble and place under a ceiling fan. The propeller will rotate. The magnets will spin producing current in the coil which will light up the LED!

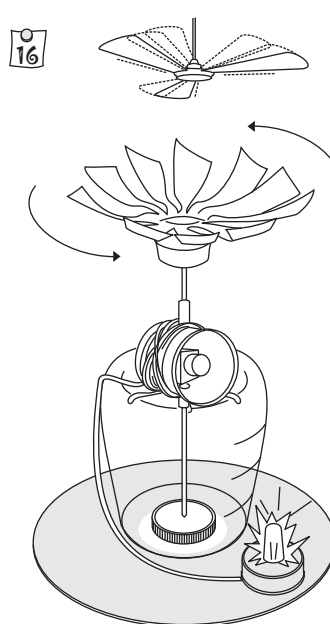

# CRANK GENERATOR

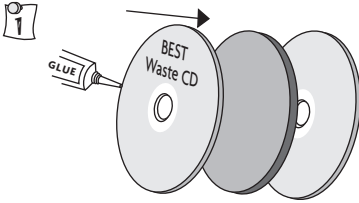
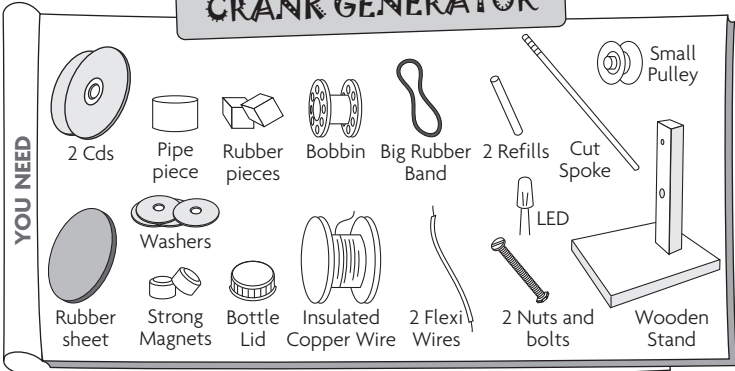

Sandwich a smaller diameter rubber between two old CDs to make a big pulley.

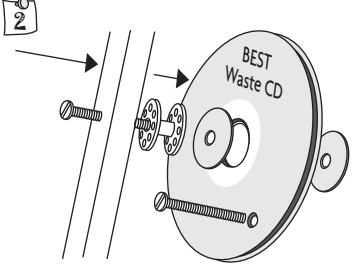

In the lower hole of the Wooden Stand place a long screw. Then put a machine bobbin, washer, CD pulley, washer and a nut. Fix a long screw handle to the CD pulley.

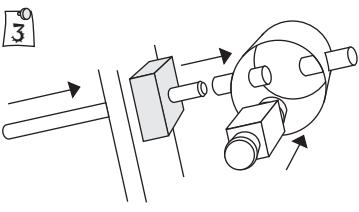

On the top hole on the Wooden Stand fix the generator pipe with two stiff straw bearings, cycle spoke axle piercing through the rubber cube. Attach two strong Neodymium magnets to the rubber cube.

4

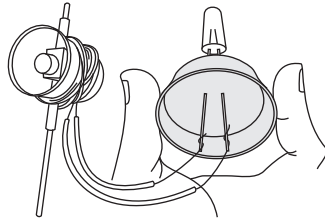

Wind 500 turns of thin insulated Copper rewinding wire on the pipe piece. Attach the ends of the coil to a LED fixed to a bottle lid.

5

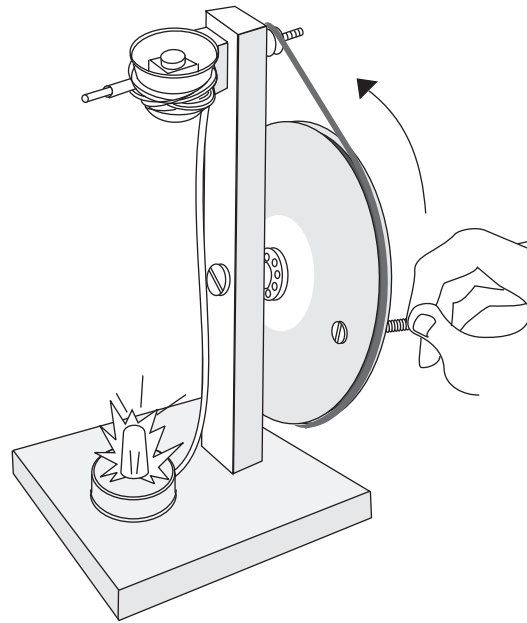

Fix a small plastic pulley on the threaded end of the cycle spoke. Join the small and big pulley with a large rubber band. On turning the handle the magnets will rotate. This spinning magnetic field will generate a current in the coil which will light up the LED!

## SYRINGE TORCH

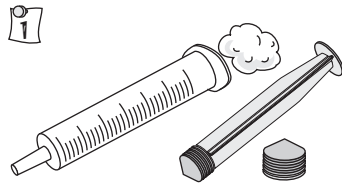
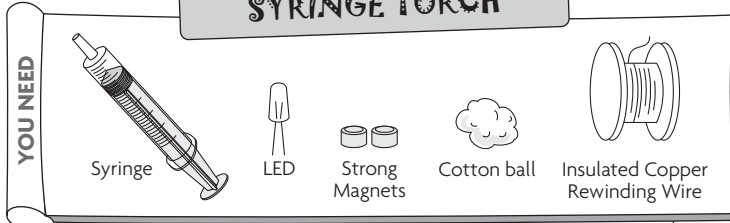

Place cotton in a syringe barrel. Remove rubber piston from the plunger.

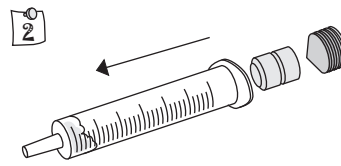

Place 2 strong magnets and insert the rubber piston as a stopper.

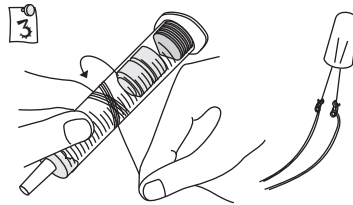

Wind 500 turns of thin insulated motor rewinding wire on the syringe. Scrape the insulation from the ends and attach them to a LED.

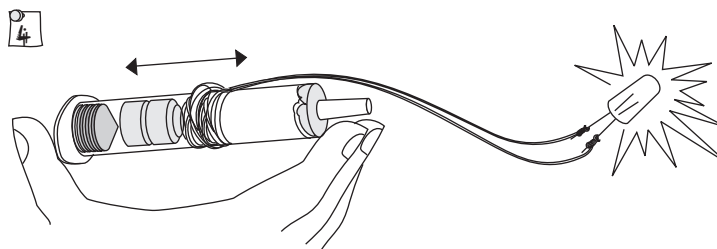

Now hold the syringe barrel and shake it. The magnets will reciprocate freely. The changing magnetic field will produce current in the coil and light up the LED.

## SIMPLEST MOTORS

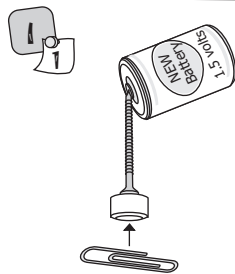
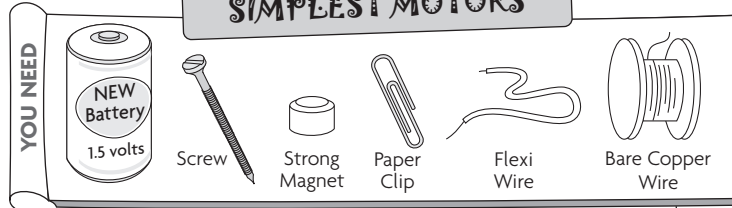

Stick a strong Neodymium magnet to the head of a pointed steel screw. Hang the screw from the battery button. Stick a paper clip to the magnet.

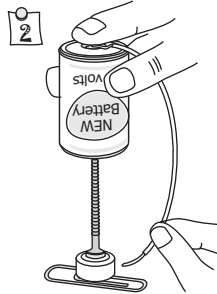

Connect one end of a wire to the flat surface of the battery. Touch the other end to the cylindrical surface of the magnet. The screw, magnet and paper clip will spin very fast. The paper clip acts like the blades of a fan.

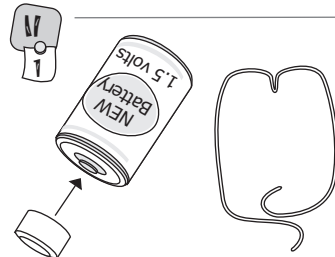
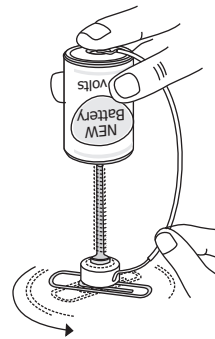

File the battery brass button flat and stick a strong Neodymium magnet to it. Take 30-cm BARE copper wire. Shape it as shown.

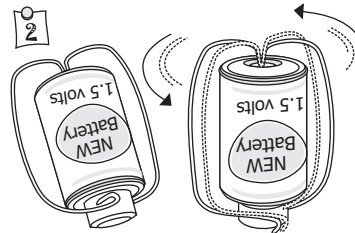

Place the wire 'V' in the dimple on the battery base. The free ends of the wire must touch the magnet. On giving the wire loop a little 'push' it will start rotating.

## MAGNETIC DIVER

YOU NEED

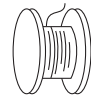
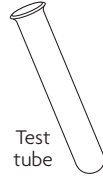
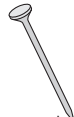

Styrofoam Ball

Nail

Test tube

Rubber base

Insulated Copper Wire

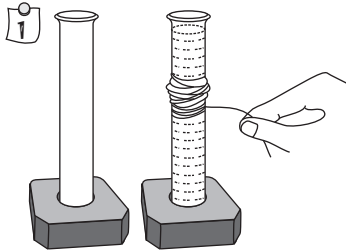

Stand a test tube with water on a rubber base. Wind 5-m of insulated copper wire.

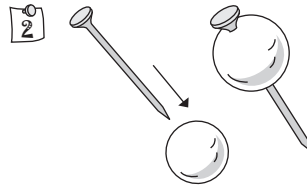

Poke a paper pin in a Styrofoam ball. The ball and pin must just float in water.

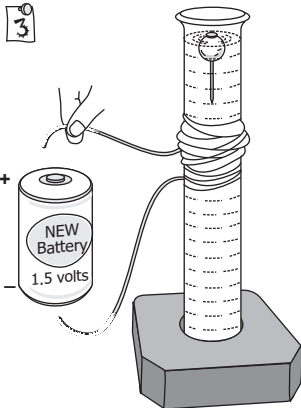

Scrape the insulation from the ends of the coil and attach them to a 1.5-volt battery.

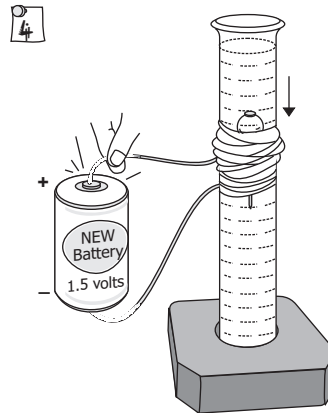

The coil will become an electro-magnet and the Pin-ball will take a deep dive. On disconnecting the battery the pin-ball diver will pop up.

## STANDING SPINNING PENCIL

YOU NEED

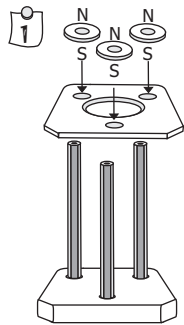
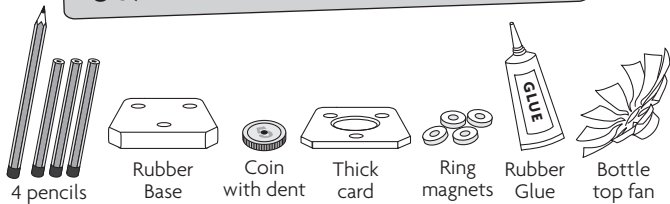

1 Stand 3 pencils on a rubber base. Stick thick card on top for support. Fix three ring magnets with same poles UP. Fix another magnet in a sharp pencil.

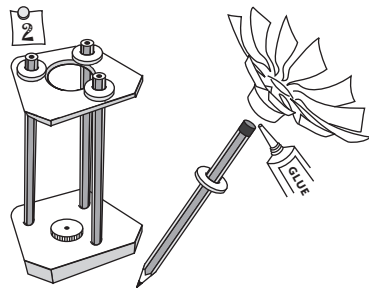

2 Stick a coin with a dent on the rubber. Make a fan from a bottle top (see page 38-39) and glue it to the middle pencil.

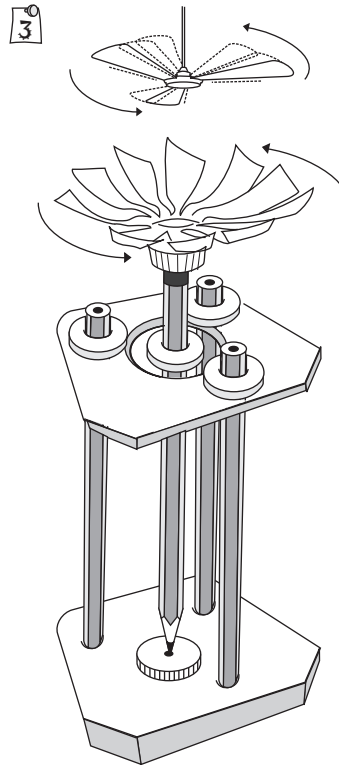

3 Adjust the central magnet to make the pencil stand on its point. Place under a ceiling fan to spin the pencil continuously.



# PENCIL BOX PERISCOPE

YOU NEED



Pencil Box



Mirrors

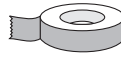

Cello tape



Scissors

1

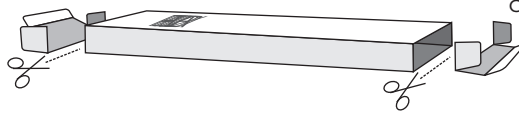

Cut the end flaps of a card sheet pencil box.

2

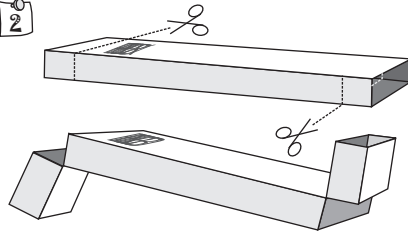

Make half cuts on both ends and bend them at right angles.

3

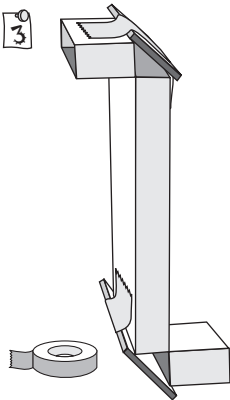

Tape two mirrors at 45-degrees to make a periscope.

4

Use the periscope to view things on the other side of a high boundary wall.

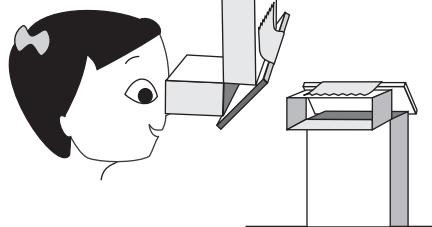

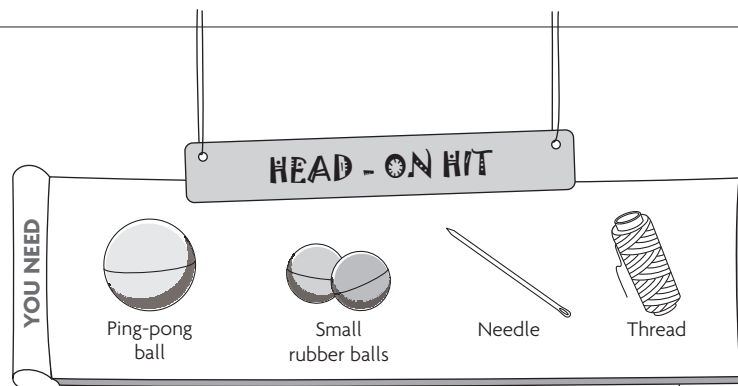

1

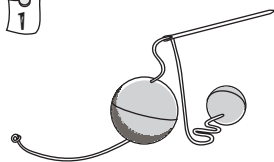

Tie two rubber balls (crazy balls) at the two ends of a 80-cm long thread. Hang the balls from the middle of the thread. The balls must touch each other. Pull out one ball and let it go.

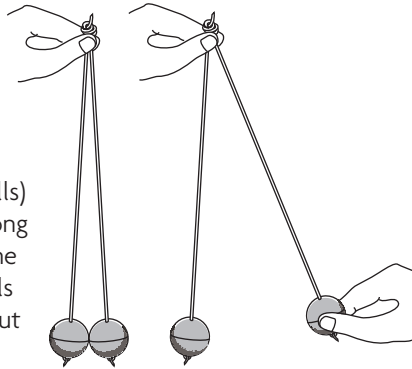

2

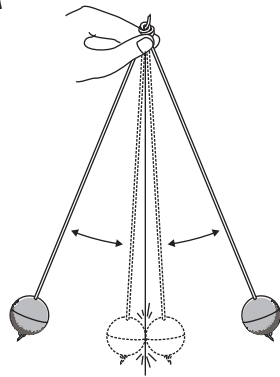

The balls will strike and being the same weight they will bounce back the same distance.

3

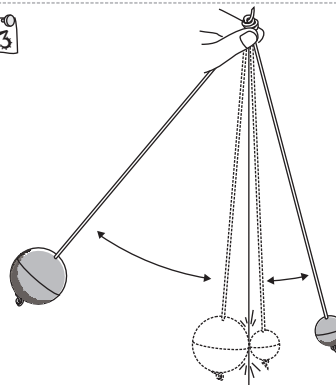

Try with a light Ping Pong Ball and a heavy rubber ball. After impact the Ping Pong Ball will go very far. This is because of conservation of momentum and energy.

## NUT SPINNER

YOU NEED



Steel Ring

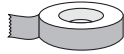

Cello tape

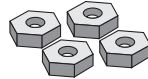

Steel Nuts

1

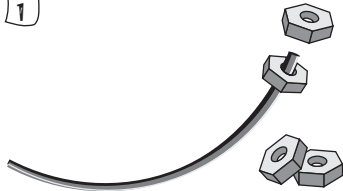

Take a steel wire ring about 30-cm in diameter. Place four loose nuts in the ring.

2

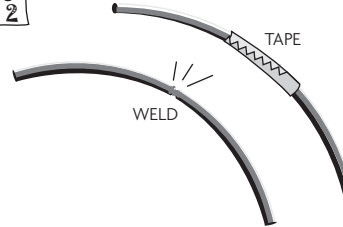

Tape the ends of the ring. You can also weld the ends.

3

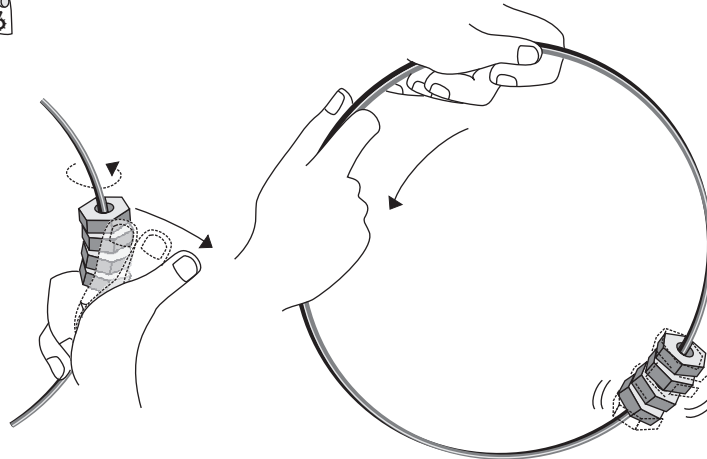

Now give the nuts a good “spin” with a flick of your thumb. Then keep turning the ring slowly. You will be surprised that you can keep the nuts “spinning” for a very long time.

## SPIRAL SNAKE

YOU NEED



1-mm thick wire

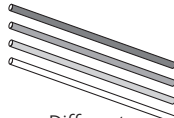

Different colored straws



Sketch Pen



Scissors

1

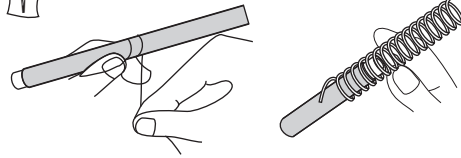

Wind 40-cm long (1-mm thick) wire on a sketch pen. Remove the spring.

2

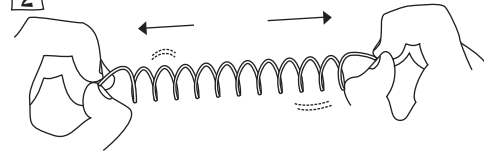

Pull spring from both ends to make a long spiral.

3

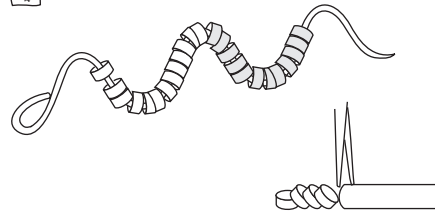

Weave color straw pieces - first dark and then light colors. Loop both ends.

4

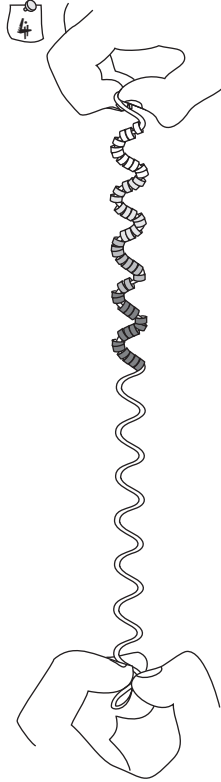

On holding vertically the straw pieces will magically spiral down like a slithery snake!

# WOODPECKER

YOU NEED



Thick card  
Woodpecker



1-mm  
thick wire

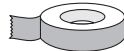

Cello tape



Toothpick



Spoke



Scissors

1

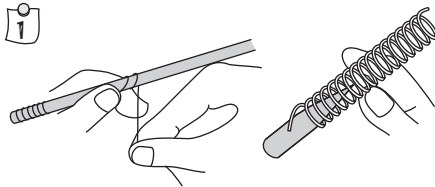

Wind 10-cm long wire on a toothpick.  
Remove the spring.

2

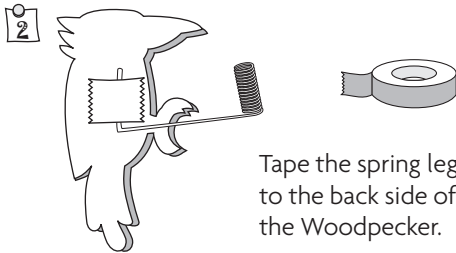

Tape the spring leg  
to the back side of  
the Woodpecker.

3

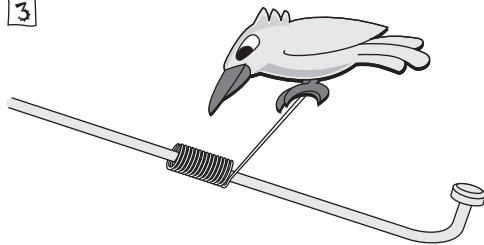

Place the spring on a slightly loose wire  
(cycle spoke).

4

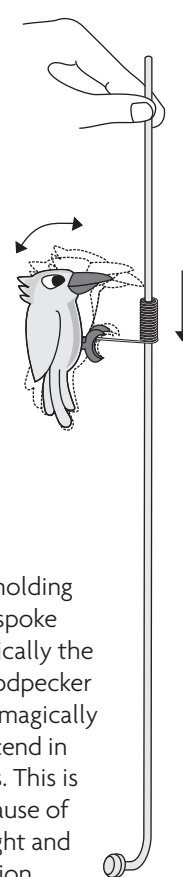

On holding  
the spoke  
vertically the  
Woodpecker  
will magically  
descend in  
jerks. This is  
because of  
weight and  
friction.

## MOUTH ORGAN

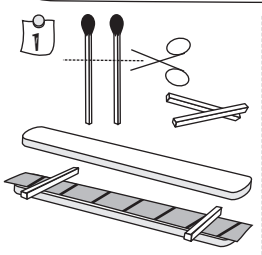
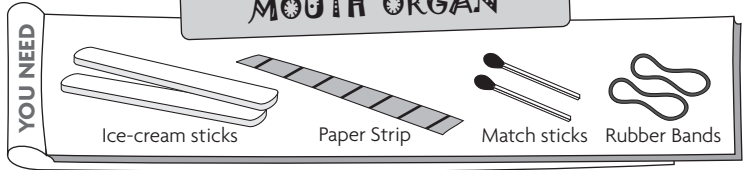

Place a long paper strip on an ice-cream stick and then place two small matchsticks near the ends. Place another ice-cream stick on top.

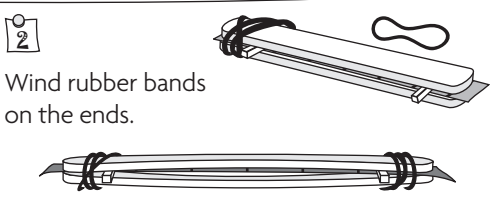

Wind rubber bands on the ends.

Now place the mouth organ in your mouth and blow to hear a musical sound.

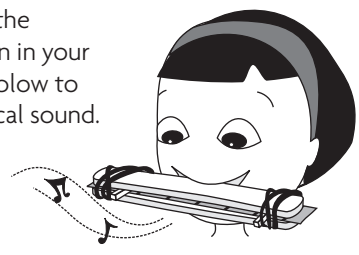

## PAPER CLIP TOP

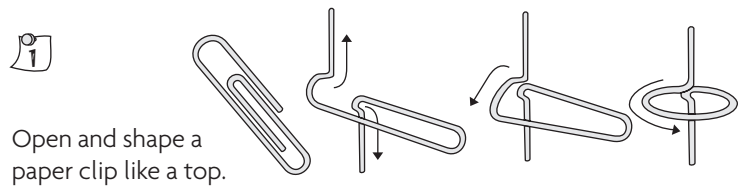

Open and shape a paper clip like a top.

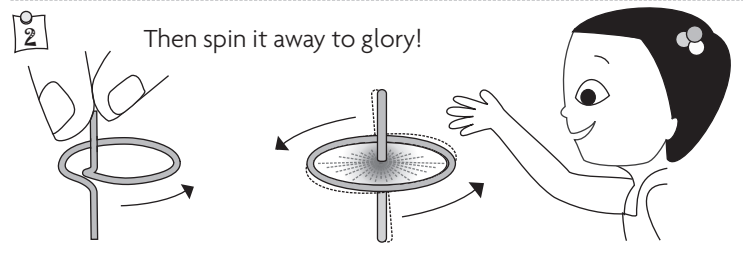

## DOG - PUPPET

YOU NEED



Styrofoam Glass



Marble



Paper



Thread



Cello Tape



Scissors

1

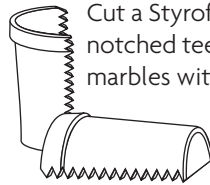
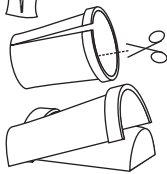

Cut a Styrofoam glass in half. Cut notched teeth and stick two marbles with tape.

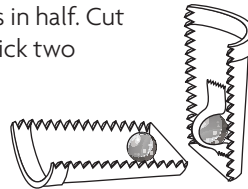

2

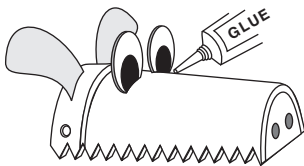
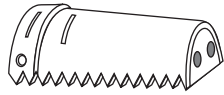
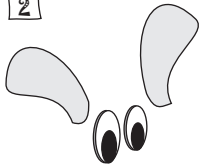

Make holes in the jaws to fix the hinge stick. Draw eyes and ears on card sheet. Paint and fix them to the upper jaw.

3

Hinge both jaws on a stick.

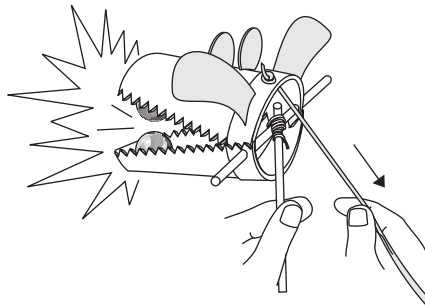
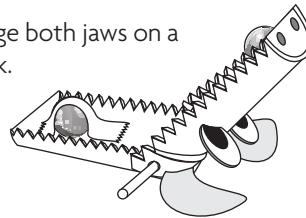

Tie a vertical stick to the cross stick. Tie a thread to the upper jaw. Hold the vertical stick. Then pull and leave the thread. The dog will open and close its mouth with a loud bark!

## SEWING MACHINE

YOU NEED

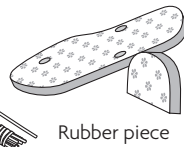
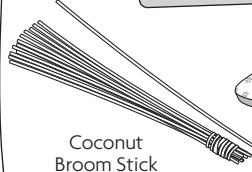

1

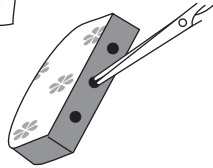

Poke three holes in a 6-cm x 3-cm rubber.

2

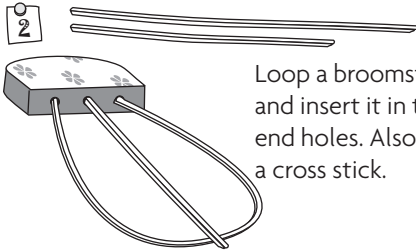

Loop a broomstick and insert it in the end holes. Also insert a cross stick.

3

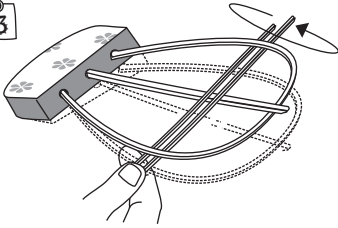

Weave two sticks as shown under the loop, over the center stick and then under the loop. Now rotate the two sticks to hear a sewing machine like sound.

4

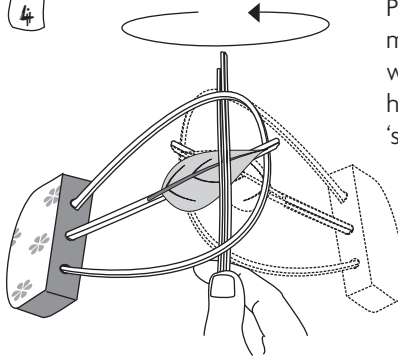

Place a leaf as shown and run the machine. After a while the leaf will be ejected out but it will have a series of holes like 'stitches'.

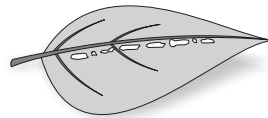



## MERRY - GO - ROUND

YOU NEED



Neem (Margosa) pods

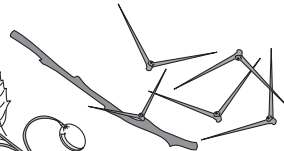

Babul (Acacia) stick and thorns



Rubber with hole



Thread

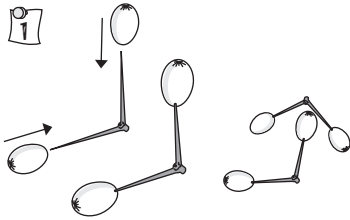

1  
Insert two soft pods in a thorn. Make several such dumbbells.

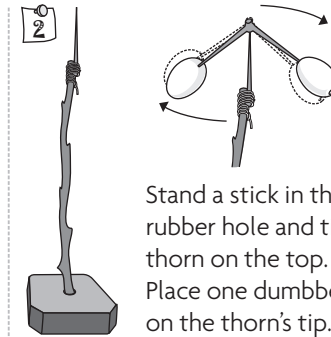

2  
Stand a stick in the rubber hole and tie a thorn on the top. Place one dumbbell on the thorn's tip.

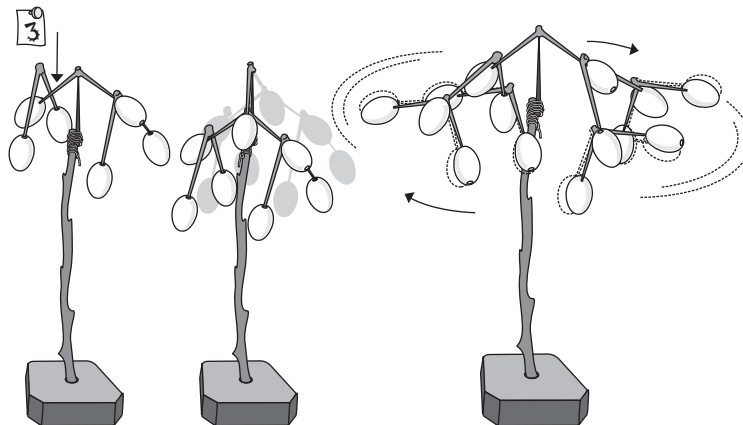

3  
Keep placing dumbbells in a balanced and symmetric way. This will make the merry-go-round stable. Then give it a gentle twirl at the center. The merry-go-round will spin for a very long time.

## MINUTE MEASUREMENTS

YOU NEED



1

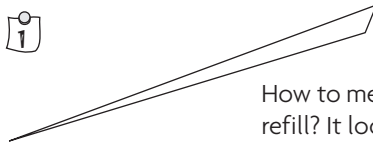

How to measure the internal diameter of a refill? It looks difficult but it's easy. Cut a taper strip from a piece of paper.

2

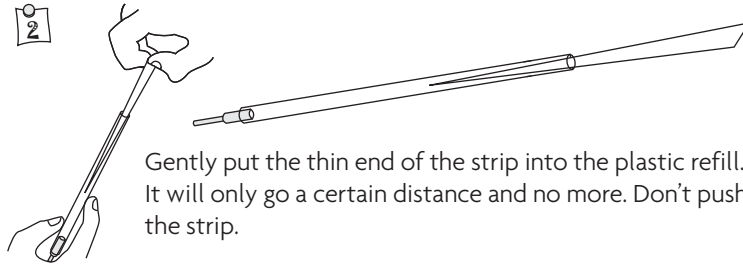

Gently put the thin end of the strip into the plastic refill. It will only go a certain distance and no more. Don't push the strip.

3

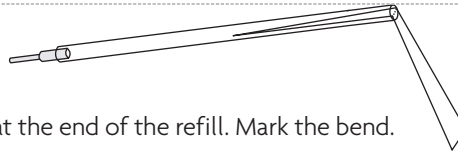

Bend the paper strip at the end of the refill. Mark the bend.

4

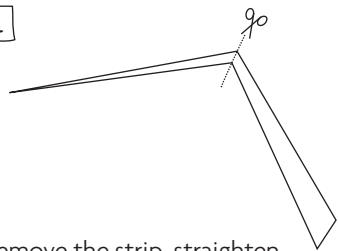

Remove the strip, straighten and cut it at the bend.

5

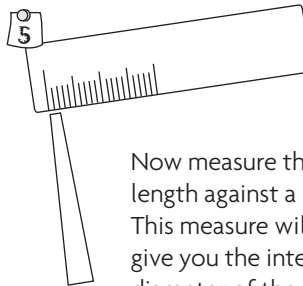

Now measure this length against a ruler. This measure will give you the internal diameter of the refill.

# NEWSPAPER BIN

YOU NEED



Newspaper

1

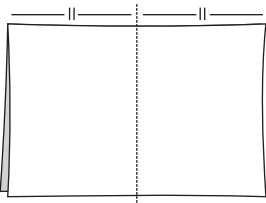

Take a full size newspaper. Fold the vertical mid-line.

2

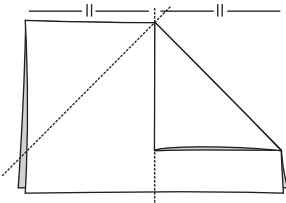

Fold top left to midline to make a triangle.

3

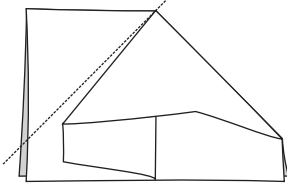

Open and flatten it to the left side.

4

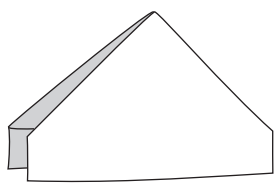

Repeat the same on the back side.

5

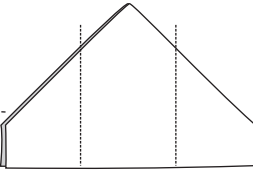

... to make a double house.

6

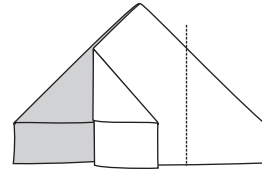

Fold the left end ...

7

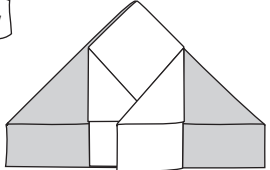

... and then right end to meet.

8

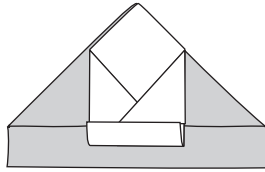

Fold bottom rectangle in half.

9

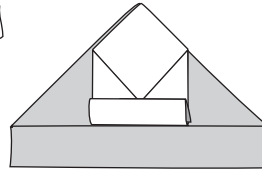

Double fold to lock.

10

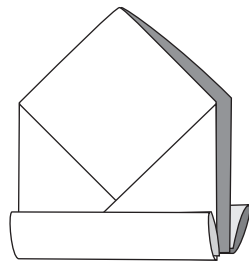

Similarly fold and lock the back side.

11

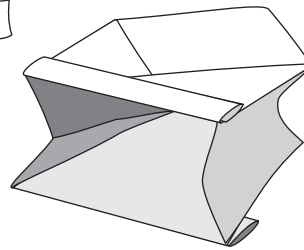

Gently open and shape the bin.

12

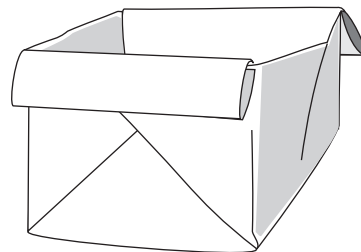

Newspaper Bin is ready...

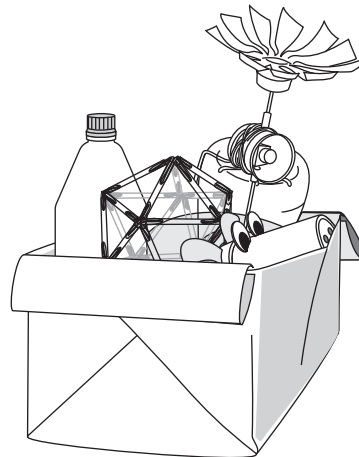

...to store sundry items.

## SIMPLE MECANNO

YOU NEED

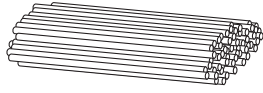

Transparent Stiff Straws



Wire



Wire Sleeve



Scissors

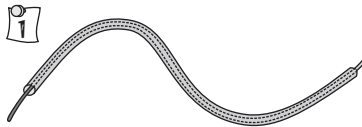

Place 1-mm thick wire in a loose wire sleeve. The wire will provide the strength and the sleeve will provide the grip.

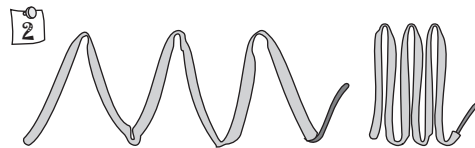

Make zigzag bends at equal distances. Bring ends together to make joints.



Lock joint by placing wire at one end in the sleeve of the other end.

4

Make two dimensional shapes triangles, squares etc using "joints-of-two" and straws.

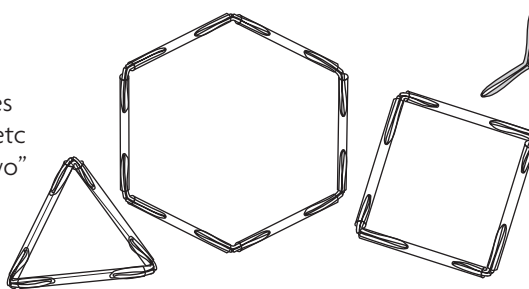

5

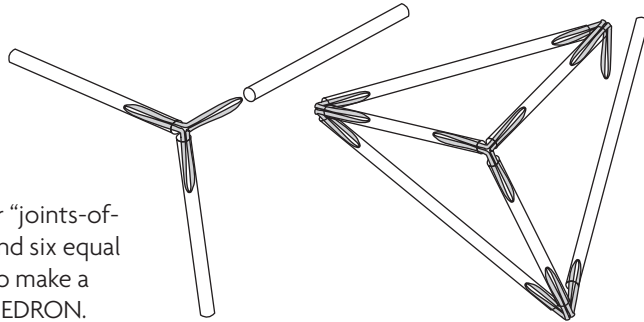

Use four "joints-of-three" and six equal straws to make a TETRAHEDRON.

6

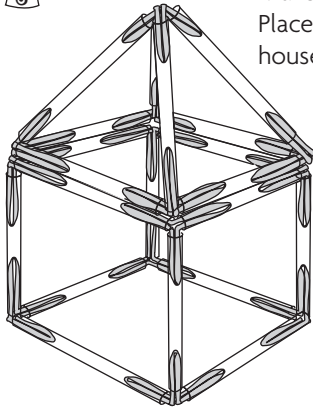

Make a CUBE and PYRAMID.  
Place them together to make a house.

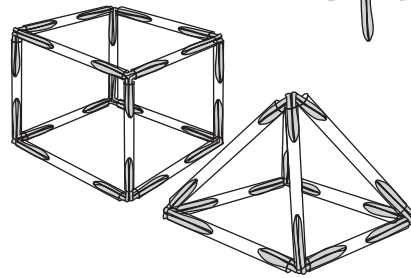

7

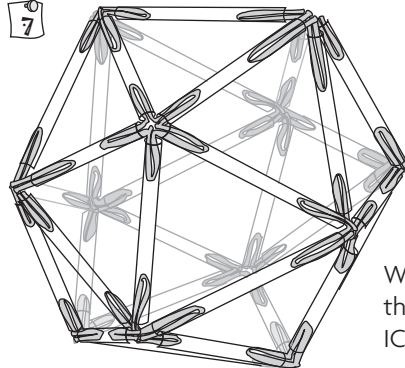

With twelve "joints-of-five" and thirty straws make an ICOSAHEDRON.

